

Shueiwan H. JUANG¹
Ming-Hsiung CHANG²
Juan-Chen HUANG³

Applying the ARPSO Algorithm to Shafting Alignment Optimization Design

Preliminary communication

Trial-and-error method for shafting alignment at the initial design stage in the shipbuilding industry is mostly carried out by shipyard designers. However, adjusting of a highly sensitive shaft line within a short period in order to obtain a reasonable positive design value for each bearing reaction force (load) and bearing pressure for the entire propulsion shafting system is very difficult. Any minor changes in the bearing location and/or off-set design values may cause different analytical results with a large design deviation, such that the final design result may not comply with the classification society requirements and manufacturers' design criteria.

The innovative ARPSO-SHAALIN design program successfully combines and integrates the Three Moment Equation Method (TMEM) for a continuous beam with the Attractive and Repulsive Particle Swarm Optimization (ARPSO) algorithm. The ARPSO algorithm searches for the values of global optimal design parameter for each bearing off-set and location of the propulsion shafting in the initial design stage in order to create a brand new optimal shafting arrangement. Design results are verified and presented.

Keywords: ARPSO (Attractive and Repulsive Particle Swarm Optimization) algorithm, optimization, high speed craft, propulsion shafting alignment, TMEM (Three Moment Equation Method)

Authors' addresses:

¹ Associate Professor, Dept. of Mechanical & Mechatronic Engineering, National Taiwan Ocean University, 2, Pein-Ning Road, Keelung 20224, Taiwan, R.O.C.

² PhD student, Dept. of Mechanical & Mechatronic Engineering, National Taiwan Ocean University, Tel.: +886-2-25062711 ext. 606; Fax: +886-2-5074722; E-mail: mhchang@crclass.org.tw

³ Assistant Professor, Dept. of Merchant Marine, National Taiwan Ocean University

Received (Primljeno): 2011-06-27

Accepted (Prihvaćeno): 2011-28-07

Open for discussion (Otvoreno za raspravu): 2013-06-30

Primjena ARPSO algoritma na optimizaciju projekta podešavanja propellerskog vratila

Prethodno priopćenje

Podešavanje (centriranje) propellerskog vratila u brodograđevnoj industriji postupkom pokušaja i pogrešaka uglavnom provode projektanti iz brodogradilišta. Međutim, fino podešavanje osjetljivih vratilnih vodova u prihvatljivim granicama točnosti za sile i pritiske u ležajevima za cijeli osovinski sustav u kratkom vremenu je vrlo zahtjevan zadatak. Svaka pa i mala promjena u položaju ležaja kao i u projektnim vrijednostima može izazvati različite rezultate s velikim odstupanjima, tako da konačni rezultat ne mora biti u skladu sa zahtjevima klasifikacijskih ustanova i projektnim kriterijima proizvođača.

Inovativni ARPSO-SHAALIN projektni program uspješno kombinira i integrira „Metodu tri momenta” (Clapeyron-ova jednadžba) s optimizacijskim algoritmom *Attractive and Repulsive Particle Swarm Optimization* (ARPSO). ARPSO algoritam određuje vrijednosti globalnog optimuma projektnih parametara za svaki pomak ležaja i položaj propellerskog vratila u odnosu na početno stanje zadano projektom, a u cilju kreiranja potpuno novog postava osovinskog voda. Rezultati projektnog proračuna su provjereni i prezentirani.

Ključne riječi: brza plovila, jednadžba tri momenta (Clapeyron-ova jednadžba), optimizacijski algoritam ARPSO, polaganje vratilnog voda

1 Introduction

Evolutionary algorithm, a computational model which is based on Darwin's theory of evolution refers to “natural selection, survival of the fittest” to mimic the natural process of biological evolution. It is different from traditional algorithms with its “random selection” and “follow nature”, which not only makes the calculating capacity of evolutionary algorithm stronger, but is also designed with the possibilities for various engineering applications and, for the robustness of its multi-field characteristics. Hence, many similar methods of evolutionary algorithms have been successfully applied in the fields of natural sciences,

social sciences or engineering design for the purpose of design optimization with more efficiency of problem solution, which is being proved in recent years. However, the most difficult issues when solving optimization problems include the following:

- (1) According to different optimization problems of searching for the dimensional space of a problem, the complexity and difficulty will increase as the dimensional space of the problem becomes higher, and when the expansion of solutions to the problems gets out of control. So, it is quite difficult to obtain the global optimal solution when searching for the higher dimensional space of problem.

(2) Comparing to single-extreme optimization problems, in case of multi-extreme problems it will become more difficult to search the best global optimal solution, since its process of algorithms cannot escape from the local optimum value to the global dimensional space for carrying out further optimum algorithms. This is especially true in Direct Search Algorithm Method.

In view of this, for the development of a global optimization algorithm method, combined with the verified theoretical design program, the best way is to search a global optimum solution. With this global optimization algorithm method, it is possible to escape easily from the local optimum value to the global dimensional space for carrying out further optimum algorithms. This new innovative design optimization algorithm will not only avoid local optimal solution, but will also improve the search efficiency and accuracy, and can thus quickly and clearly meet the needs of researchers.

Meanwhile, the main purpose in this study is to use the design methodology of three moment equation method (TMEM) [1] to calculate each supporting bearing load and its bending moment on the whole shafting at the initial design stage of shafting alignment. Basically, this theorem regards the shafting as a continuous beam, the supporting bearing as the rigidity body, and the deflection between the hull and the supporting bearing is regarded as an elasticity support in the design methods. The aforesaid concept of the continuous beam with rigid supporting bearings is commonly accepted by academics in colleges, and by the shipbuilding industry.

Furthermore, the TMEM design methodology has been proved by S.-W. Juang and M.-H. Chang [2] and presented at the 7th International Symposium on Marine Engineering, Tokyo, Japan in October 2005. In this paper the authors described its basic theoretical derivation to the real shafting design model and made comparison with other design results from the Finite Element Method and the shipyard original design, and verified their design results in precision.

The TMEM design methodology of shafting is mostly adopted by many shipyards for the reason of easy to input design parameter and easy operation using a portable computer especially for checking the calculation results with the on board jack up test to bearings' load.

For example, some of the most famous shipbuilding companies in Asia, such as *Mitsui Heavy Industry (MHI) Co.*, in Japan, *Kawasaki Heavy Industry (KHI) Co.*, in Japan, *Ishigawajima-Harima Heavy Industry (HHI) Co.*, in Japan, and *China Shipbuilding Corporation* at Keelung and Kaohsiung Shipyards (*CSBC Keelung and Kaohsiung*) in Taiwan, and the local ship's design company, *United Ship Development and Design Center* in Taiwan (*USDDC*, Taiwan) adopted this same design theorem in the early days. The TMEM is still being used in major design tasks of the shafting alignment in some shipyards in the world.

In this research topic of the application of the global optimization algorithm in the design of propulsion shafting alignment for high speed craft, we use the design theorem of TMEM as an interface tool for the calculation of each bearing load and bearing pressure, and the bending moment on the propulsion shafting. Nevertheless, all of the formulae based on TMEM design methodology are programmed in Fortran for the calculation of design using Computer Aided Design (CAD).

Meanwhile, all of the above mentioned output results calculated from the TMEM Fortran program will be automatically

connected to another global optimization function of Fortran program for the purpose of the optimization algorithm based on the theory on ARPSO, Attractive and Repulsive Particle Swarm Optimization [3], a global optimization algorithm method, searching for the optimal values of each bearing off-set and each bearing location on the design of propulsion shafting alignment system for high speed craft.

The design objectives to be achieved by using the ARPSO-SHAALIN design program are to make sure to obtain the uniform distribution values for each bearing reaction force (load), and to minimize the bearing pressure in a positive design range, and also to get an optimal adjusted bearing location when the new propulsion shafting is recreated and arranged.

The design operation criteria are to make sure that the propulsion shafting is operating within the limitation design range of each bearing load, bearing pressure, shaft bending moment, and shearing force in order to comply with the design criteria and standards of the maker and Rule's requirements from Classification Societies.

Hence, we can call the integrated Fortran Program on the ARPSO algorithm as an ARPSO-SHAALIN Program, a newly innovative hybrid method on global optimization algorithm, which is combined with the design theory of the TMEM and ARPSO algorithm coding on its software in Fortran Program for the purpose of optimization design of propulsion shafting alignment. It is useful and functional for searching the optimization bearing off-set value and bearing location for each bearing at the initial design stage of shafting arrangement.

As a result of the verification of a real design case for a high speed craft propulsion shafting system, this algorithm design system of ARPSO has shown to be fast and its output results precise and reliable. The advantages of study of this ARPSO algorithm design program is not only to provide a global optimum solution results for propulsion shafting design and arrangement, but also to provide a designer with a reliable and fast program, offering him the benefits of cost and manpower savings.

2 Study approach

- (1) Modeling a direct propulsion shafting system of high speed craft as illustrated in Figure 1 [4]. It includes the main component element to this propulsion system such as: main engine, shaft input coupling flange between main engine and reduction gear, reduction gear, shaft output coupling flange between reduction gear and No.1 intermediate shaft, 1st intermediate shaft, No.2 shaft coupling between the 1st intermediate shaft and the 2nd intermediate shaft, 2nd intermediate shaft, No.3 shaft coupling between the 2nd intermediate shaft and the propeller shaft, forward shaft strut, propeller shaft, aft end shaft strut and, propeller and its accessories.
- (2) Study on the basic TMEM design theoretical of shafting alignment, and then new coding of all the formulation of derivation from the TMEM design methodology in Fortran Program for computer aided design (CAD) as required.
- (3) Verification and comparison of the design output result of each supporting bearing load with some other real design projects for propulsion shafting system in high speed craft. The purpose of this verification is to check the reliability and precision in calculating and designing propulsion shafting alignment with the TMEM design program.

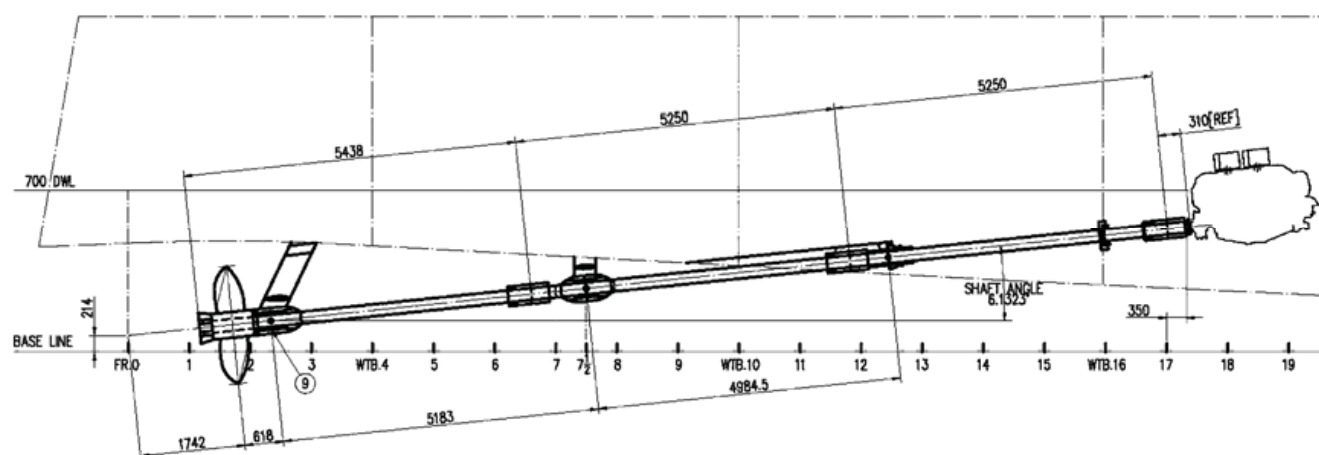

Figure 1 Direct coupling of shafting system [4]
Slika 1 Direktni spoj osovinskog voda [4]

- (4) Study on the theory of ARPSO for the purpose of global optimization algorithm on the design of propulsion shafting alignment for upgrading and the optimization of design quality on the best alignment of shafting arrangement.
- (5) New coding of all the design formulation from ARPSO design methodology in Fortran 95 program for computer aided design (CAD) as required.
- (6) Combining these two (TMEM and ARPSO) design programs to be an integrated one for the design calculation and analysis of propulsion shafting with the ARPSO global optimum algorithm. It means that TMEM Fortran program is to be an interface tool for the calculation of each bearing reaction force (load) and the bending moment on the propulsion shafting. These calculation results will be employed to the ARPSO Fortran program for further analysis of the object value in optimization at each stage of calculation. When the one of the particles finds the optimum value, the other particles will change and follow this route and move to the same way to find their global optimum and best position accordingly.
- (7) Finally, design case study for a real propulsion shafting as shown in Figure 1 will be adapted in our calculation, analysis and optimization of the optimum values of each supporting bearing load and location in order to achieve an optimum design of the propulsion shafting.

Meanwhile, all these results after carried out global optimization algorithm will be compared with the original design values from the shipyards. As a result of the study, we will obtain the optimum shafting align values for each bearing reaction force (load) and location under the same design criteria and condition. Hence, the reliability and accuracy of using these Hybrid (TMEM and ARPSO) Fortran programs based on two design methodologies to optimize the optimum bearing loads and optimum bearing location in the real case of shafting are verified and shown.

3 Design purpose and flow-chart of ARPSO algorithm

3.1 Design purpose of ARPSO algorithm

As we know from some of the current shipyard design status on propulsion shafting arrangement and alignment, the

trial-and-error method is being applied to design and find out the useful shafting arrangement design data on bearing reaction and bearing pressure, but without optimization arrangement on the propulsion shafting.

The design result obtained by the trial-and-error method may cause a non-uniform or over excessive bearing reaction force and pressure on propulsion shafting. This phenomenon will cause a significant damage on the shaft strut bearings and/or the stern tube bearing of the propulsion shafting system due to misalignment as shown in Figure 2 and also damage to the reduction gear and the main engine driving equipment subsequently.



Figure 2 Excessive wastage and crack to a damaged aft shaft strut bearing
Slika 2 Nedopušteno velika istrošenost i pukotine oštećenog ležaja stražnjeg osovinskog skroka

In view of the above problems related to the designing of shafting alignment, we need to study and solve this design problem on propulsion shafting system in the best possible way. For the purpose of this study, we will apply the global optimization algorithm based on the ARPSO design theory to optimize and find out the global best values of bearing off-set and bearing

location in each supporting bearing point for the propulsion shafting system in the cold static condition and the hot condition with rising temperature on the reduction gear bearings to the shafting alignment of high speed craft.

This means that a brand new propulsion shafting arrangement with the ARPSO design algorithm result will be produced and created after successful calculation and analysis by ARPSO-SHAALIN Program.

The design target is to re-distribute each bearing reaction force in uniform load, and also to minimize each bearing pressure in positive design range especially on the aft shaft strut, forward shaft strut, stern tube bearing, and output and input end reduction gear bearings to comply with the regulation requirements of the Classification Societies and the design stipulations from the makers.

3.2 Design flow chart of ARPSO algorithm

In order to design the flow chart based on ARPSO theory, we need to initialize the particle's position and velocity first, and then, to find the fitness values j on each individual particle, as the design flow chart illustrates in Figure 3.

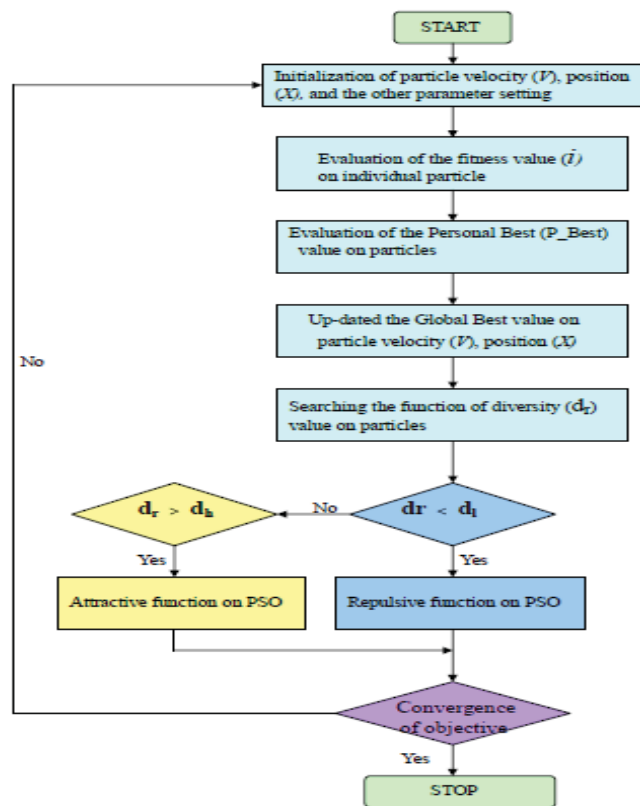

Figure 3 Flow chart of ARPSO Algorithm
Slika 3 Dijagram toka ARPSO algoritma

After that it is necessary to evaluate the personal best values and group best values through the set function of searching diversity (d_r) in low or high diversity levels. When the set function of searching diversity (d_r) is lower than the low searching diversity (d_{low}), the program system will choose the Repulsive Particle Swarm Optimization (RPSO) algorithm.

In the reverse case, if the set function of searching diversity (d_r) is higher than the high searching diversity (d_{high}), the program system will choose the Attractive Particle Swarm Optimization (PSO) algorithm accordingly.

Finally, the ARPSO-SHAALIN program system will converge all the design objectives as well as optimization to the shafting system as it can do. However, all the optimization design objectives need to be verified against the original design value from the shipyard.

In addition to the above description of the ARPSO design approaches, there are two design conditions related to the same case of propulsion shafting system that will be adopted in this study:

- Cold static condition for a straight line shafting, and
- Hot condition in which the rise of temperature is controlled by adjusting the bearing off-set valve on the out put end of the reduction gear bearing.

In the first stage, all the output design results from the shafting in the cold static condition will be compared with the original design result from the shipyards. The main point on this optimization design of the propulsion shafting system will produce a brand new propulsion shafting system with the new design result to re-locate each supporting bearing point and re-distribute each bearing load uniformly, which is better than the original design result from the shipyard.

In the second stage, we will use the new shafting arrangement design data in the cold static condition, obtained by the above ARPSO algorithm design program to re-arrange a new propulsion shafting system, and to recalculate each bearing reaction force and pressure stipulated within our design objectives.

Thus, in the hot shafting design condition, these new design data of shafting arrangement plus the raising of the bearing off-set valves at the output end of the reduction gear shaft bearing are used, assuming that the propulsion system is running with temperature rising on the both ends of the reduction gear bearings.

It should be also noted that the hot condition of the shafting alignment is designed on the basis of the new cold static shafting line in the above case plus with raising the bearing off-set valves on output end of reduction gear shaft bearing for the purpose of carrying out the ARPSO global optimization algorithm on the design of propulsion shafting alignment for high speed craft.

Finally, the main purpose of this design according to the above conditions is to make sure and verify that these design results are not only in compliance with all the necessary design criteria of the maker and Classification Societies, but are also better than the original design.

4 Theoretical background on ARPSO (Attractive and Repulsive Particle Swarm Optimization)

4.1 Evolutionary algorithms on ARPSO

The authors in [3] proposed a new algorithm method called Attractive and Repulsive Particle Swarm Optimization (ARPSO), one of the Particle Swarm Optimization (PSO) variants, which is however, based on the same characteristics of Particle Swarm Optimization for the same computing process and structure.

Regarding the Repulsive Particle Swarm Optimization (RPSO) algorithm, it has improved the original PSO algorithm for

the solution space in search of defects that may not go far enough. Meanwhile, the RPSO is more robust in searching solution space when compared to the original PSO algorithm.

On the basis of the above brief description of the characteristics of the PSO algorithm and RPSO algorithm, and therefore, a global optimization algorithm, the Attractive and Repulsive Particle Swarm Optimization (ARPSO) is to combine with PSO algorithm and RPSO algorithm in the study.

The ARPSO algorithm has not only the capabilities of the PSO mutual aggregation ability from its individual and group particles for the final convergence to the optimal solution, but also has the RPSO rejection ability of each optimal particle to expand their searching space for a better optimal solution again. This main function of the RPSO is to avoid limitations in the local optimal solution, when only the PSO algorithm is used.

Hence, it can be robustly operated and computed both in exploitation and exploration conditions in various engineering problems.

4.2 ARPSO formulation

As we know, the ARPSO algorithm has evolved from the algorithms of PSO and RPSO. Basically, each particle on current step iteration has its own new position and velocity vector after change to the next step iteration for optimization algorithm.

So, the formula of the next step iteration on particle's velocity vector and position form Attractive PSO (PSO) is express in Eqs. (1) and (2) as follows:

$$v_{i,j}^{(r+1)} = wv_{i,j}^{(r)} + c_1 r_{1,j} (y_{i,j}^{(r)} - x_{i,j}^{(r)}) + c_2 r_{2,j} (\hat{y}_j^{(r)} - x_{i,j}^{(r)}) \quad (1)$$

$$x_{i,j}^{(r+1)} = x_{i,j}^{(r)} + v_{i,j}^{(r+1)} \quad (2)$$

The major function of PSO is to possess a strong and fast convergence function concerning the problems of optimization algorithm in most cases. But sometimes the PSO algorithm will engage in the problem of searching a local optimum, and could not find the global optimum, causing deviation and/or error in some design case of higher searching diversity.

Hence, the RPSO will be employed with PSO in order to improve this situation of obtaining a local optimum on PSO. In RPSO, we mainly set the personal best learning factor C_1 and the group best learning factor C_2 both in a negative (-) value in order to repulse the group best particles limit on the same space into the other solution searching space for a better new group best and new global optimization.

Finally, the formula of the next step iteration on particle's velocity vector and position form RPSO is expressed in Eqs. (3) and (4) as:

$$v_{i,j}^{(r+1)} = wv_{i,j}^{(r)} - c_1 r_{1,j} (y_{i,j}^{(r)} - x_{i,j}^{(r)}) - c_2 r_{2,j} (\hat{y}_j^{(r)} - x_{i,j}^{(r)}) \quad (3)$$

$$x_{i,j}^{(r+1)} = x_{i,j}^{(r)} + v_{i,j}^{(r+1)} \quad (4)$$

Comparing equation (3) of RPSO with equation (1) of PSO, it can be seen that all particles normally would not gather in the same way given by the best experimental values for individual particles and group particles. Concerning the behavior of individual particles, they will search and adjust to the best space according to the diversity of the objectives, improving in such a way the optimal solution.

When the diversity values in searching are lower than the limit set value of d_{low} , the ARPSO will automatically choose the RPSO for algorithm as shown in equation (3). It means that the individual particle will jump out and repulse from the previous local best solution, searching once again the other best space of solution to find out the global optimal solution as possibly as it can.

However, if the diversity values in searching are higher than the limit set value of d_{high} , the ARPSO will automatically chose the PSO for algorithm as shown in Equation (1). It means that the individual particle will gather again and search towards the best global space of solutions.

So, we may set the virtual code of function in searching diversity as follows in Eq. (5):

$$\begin{aligned} \text{if } (d_r < d_{low}) \text{ sign}(d) &= -1; \\ \text{if } (d_r > d_{high}) \text{ sign}(d) &= 1 \end{aligned} \quad (5)$$

While the function mark of $\text{sign}(d)$ shown in Eq. (5) is -1 or 1, the ARPSO algorithm will automatically choose design method of the PSO or the RPSO for optimization algorithm. Meanwhile, the formulation on searching diversity $\text{sign}(d_r)$ is also presented as follows in Eq. (6):

$$d_r = \frac{1}{Np \cdot L} \cdot \sum_{i=1}^{Np} \sqrt{\sum_{j=1}^L (x_{i,j} - \bar{x}_j)^2} \quad (6)$$

As a result, the ARPSO algorithm can be rewritten as Eqs. (7) and (8)

$$v_{i,j}^{(r+1)} = wv_{i,j}^{(r)} + \text{sign}(d_r)(c_1 r_{1,j} (y_{i,j}^{(r)} - x_{i,j}^{(r)}) + c_2 r_{2,j} (\hat{y}_j^{(r)} - x_{i,j}^{(r)})) \quad (7)$$

$$x_{i,j}^{(r+1)} = x_{i,j}^{(r)} + v_{i,j}^{(r+1)} \quad (8)$$

5 Theoretical background of TMEM (Three Moment Equation Method)

In this section, a theoretical derivation to the shafting model shown in Figure 1 using the TMEM design methodology is being applied [2]. The basic assumption of this theorem regards the beam as a continuous beam, the supporting bearing as a rigid body, and the hull deformation between the hull shell and supporting bearing point is regarded as an elasticity support.

A free body diagram of the beam element whose basic assumption and positive nodal displacements, rotations, forces, and moments are shown in Figure 4 is as follows:

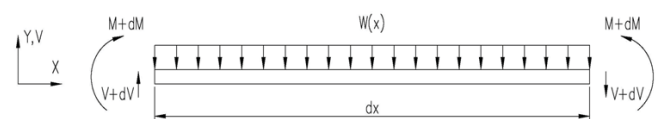

Figure 4 Free body diagram of beam element
Slika 4 Dijagram oslobođenog tijela grednog elementa

The continuous beam method is the basic principle of the TMEM while designing the shafting alignment for high speed craft as shows in Figure 5.

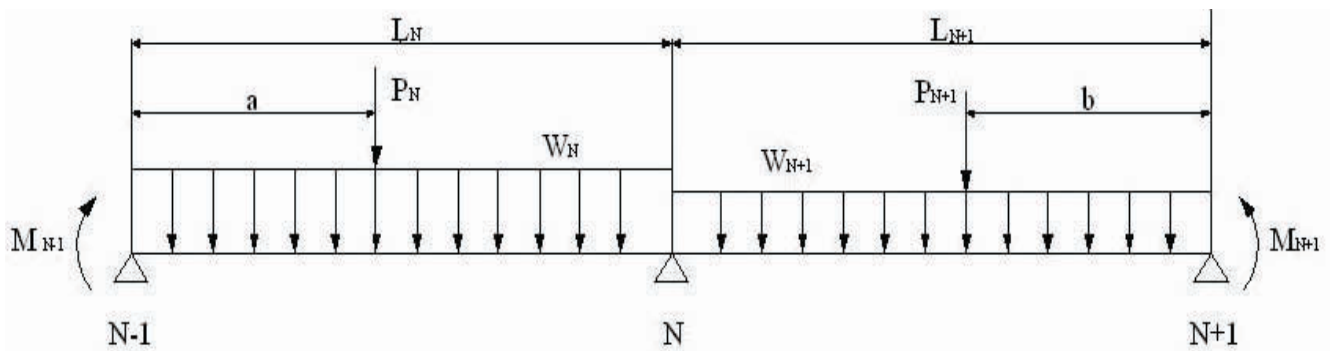

Figure 5 The illustration for shafting analysis using TMEM
 Slika 5 Prikaz analize osovinskog voda upotrebom metode TMEM

Figure 5 shows a continuous beam supported by three fixed supporting points. The symbol N indicates a middle supporting point in the beam. The symbol N-1 indicates a supporting point on the left side, and N+1 indicates a supporting point on the right side along with its beam length of segment L_N and L_{N+1} at each end separately.

The symbols W_N and W_{N+1} are the uniform load acting on the length of segment L_N and L_{N+1} at each end respectively. On this occasion, there are two concentrated loads of P_N and P_{N+1} acting on the length of segment L_N and L_{N+1} at each end simultaneously.

The deflection angles θ_N and θ'_N due to the uniform load on the beam segment are shown in Figure 6.

Figure 6 shows the N supporting point dividing the continuous beam into the left side length of segment L_N and the right side length of segment L_{N+1} . While the distributed load W_N and the moments M_{N-1} and M_N are acting on the left side of segment L_N , the deflection angle θ_N and reflection force R_N are expressed as Eqs. (9) and (10).

$$\theta_N = -\frac{W_N L_N^3}{24EI_N} - \frac{M_N L_N}{3EI_N} - \frac{M_{N-1} L_N}{6EI_N} \quad (9)$$

$$R_N = \frac{W_N L_N}{2} + \frac{M_{N-1} - M_N}{L_N} \quad (10)$$

Similarly, to apply the distributed load W_{N+1} and the moments M_N and M_{N+1} acting on the right side length of segment L_{N+1} , the

deflection angle θ'_N and reaction force R'_N are expressed as Eqs. (11) and (12).

$$\theta'_N = \frac{W_{N+1} L_{N+1}^3}{24EI_{N+1}} + \frac{M_N L_{N+1}}{3EI_{N+1}} + \frac{M_{N+1} L_{N+1}}{6EI_{N+1}} \quad (11)$$

$$R'_N = \frac{W_{N+1} L_{N+1}}{2} + \frac{M_{N+1} - M_N}{L_{N+1}} \quad (12)$$

If we apply the concentrated loads P_N and P_{N+1} to either sides of this continuous beam as shown in Figure 7, the deflection angles at θ_N , θ'_N , and the reflection forces of R_N , R'_N are represented as Eqs. (13), (14), (15) and (16) as follows.

$$\theta_N = -\frac{P_N a}{6I_N L_N} (L_N^2 - a^2) - \frac{W_N L_N^3}{24EI_N} - \frac{M_N L_N}{3EI_N} - \frac{M_{N-1} L_N}{6EI_N} \quad (13)$$

$$R_N = \frac{P_N a}{L_N} + \frac{W_N L_N}{2} + \frac{M_{N-1} - M_N}{L_N} \quad (14)$$

$$\theta'_N = \frac{P_{N+1} b}{6I_{N+1} L_{N+1}} (L_{N+1}^2 - b^2) + \frac{W_{N+1} L_{N+1}^3}{24EI_{N+1}} + \frac{M_N L_{N+1}}{3EI_{N+1}} + \frac{M_{N+1} L_{N+1}}{6EI_{N+1}} \quad (15)$$

Figure 6 The deflection angles θ_N and θ'_N due to uniform load
 Slika 6 Kutevi savijanja θ_N i θ'_N u slučaju jednolikog opterećenja

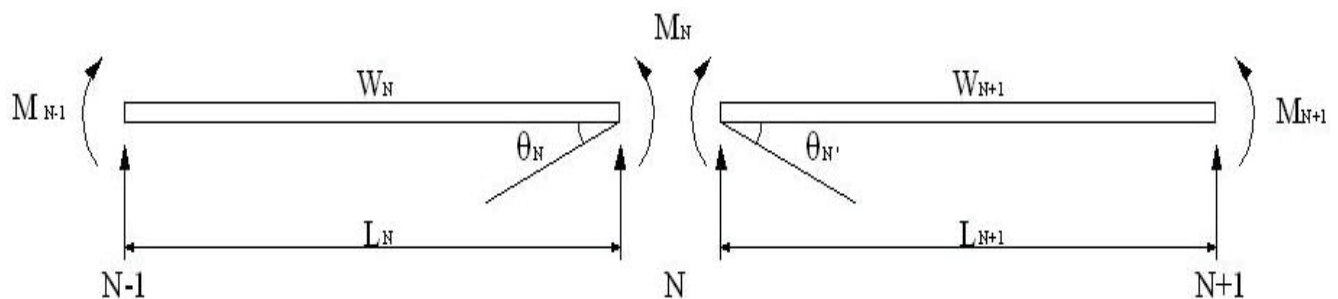

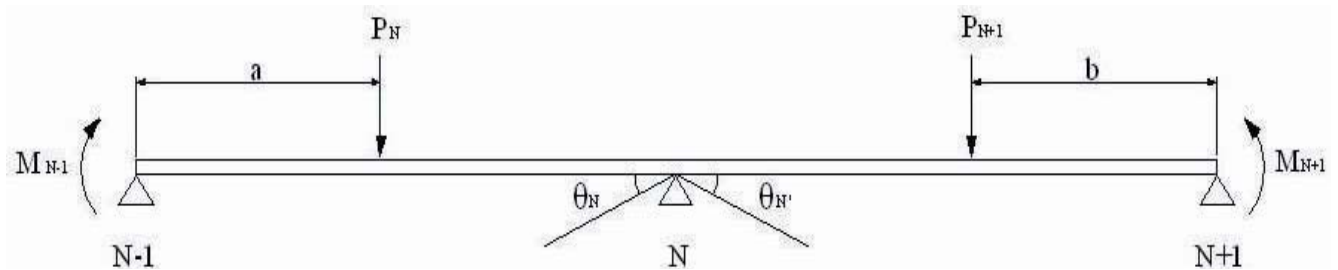

Figure 7 The deflection angles at θ_N, θ'_N due to uniform load and concentration load
 Slika 7 Kutevi savijanja θ_N, θ'_N u slučaju jednolikog i koncentriranog opterećenja

$$R'_N = \frac{P_{N+1}b}{L_{N+1}} + \frac{W_{N+1}L_{N+1}}{2} + \frac{M_{N+1} - M_N}{L_{N+1}} \quad (16)$$

$$\beta_{N+1} = \frac{\delta_N - \delta_{N+1}}{L_{N+1}} = -\frac{\delta_{N+1} - \delta_N}{L_{N+1}} \quad (20)$$

Since this is a continuous beam, then the deflection angle $\theta_N = \theta'_N$ at the N supporting point. Meanwhile, the reaction forces at the N supporting point are obtained from the superposition of R_N and R'_N on either sides of this supporting point. Simplifying and rearranging Eqs. (13), (14), (15) and (16), we obtain:

$$\begin{aligned} M_{N-1} \left(\frac{L_N}{I_N} \right) + 2M_N \left(\frac{L_N}{I_N} + \frac{L_{N+1}}{I_{N+1}} \right) + M_{N+1} \left(\frac{L_{N+1}}{I_{N+1}} \right) = \\ = -\frac{W_N L_N^3}{4I_N} - \frac{W_{N+1} L_{N+1}^3}{4I_{N+1}} - \frac{P_N a}{L_N I_N} (L_N^2 - a^2) - \\ - \frac{P_{N+1} b}{I_{N+1} L_{N+1}} (L_{N+1}^2 - b^2) \end{aligned} \quad (17)$$

$$\begin{aligned} R_N = \frac{M_{N-1} - M_N}{L_N} + \frac{M_{N+1} - M_N}{L_{N+1}} + \frac{P_N a}{L_N} + \\ + \frac{P_{N+1} b}{L_{N+1}} + \frac{W_N L_N}{2} + \frac{W_{N+1} L_{N+1}}{2} \end{aligned} \quad (18)$$

If the continuous beam does not lie on a horizontal straight line, the offset influence angles β_N and β_{N+1} are to be considered in Eqs. (19), (20), and the illustration of the offset influence angles is given in Figure 8.

$$\beta_N = \frac{\delta_{N-1} - \delta_N}{L_N} \quad (19)$$

Figure 8 The illustration for offset influence angles β_N and β_{N+1}
 Slika 8 Prikaz za izdvojene utjecajne kuteve β_N i β_{N+1}

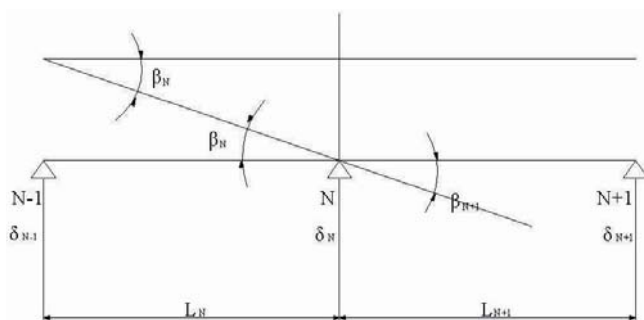

Hence, we derive the Eqs. (19) and (20) into the Eq. (17), and then, we have another formula in Eq. (21)

$$\begin{aligned} M_{N-1} \left(\frac{L_N}{I_N} \right) + 2M_N \left(\frac{L_N}{I_N} + \frac{L_{N+1}}{I_{N+1}} \right) + M_{N+1} \left(\frac{L_{N+1}}{I_{N+1}} \right) = \\ = -\frac{W_N L_N^3}{4I_N} - \frac{W_{N+1} L_{N+1}^3}{4I_{N+1}} - \frac{P_N a}{L_N I_N} (L_N^2 - a^2) - \\ - \frac{P_{N+1} b}{I_{N+1} L_{N+1}} (L_{N+1}^2 - b^2) - 6E \left(\frac{\delta_{N-1} - \delta_N}{L_N} + \frac{\delta_{N+1} - \delta_N}{L_{N+1}} \right) \end{aligned} \quad (21)$$

Simultaneously, the corresponding reaction force to the N supporting point for this continuous beam is obtained as Eq. (22)

$$\begin{aligned} R_N = \frac{M_{N-1} - M_N}{L_N} + \frac{M_{N+1} - M_N}{L_{N+1}} + \frac{P_N a}{L_N} + \\ + \frac{P_{N+1} b}{L_{N+1}} + \frac{W_N L_N}{2} + \frac{W_{N+1} L_{N+1}}{2} \end{aligned} \quad (22)$$

Equations (21) and (22) above are yielded for CLAPEYRON's theorem on continuous beam, and basically this theory will be applied to calculate the bearing loads and bending moments of shafting alignment for high speed craft.

6 Global optimization algorithm in designing propulsion shafting alignment

In this chapter, we will apply the innovative Fortran design program herein called ARPSO-SHAALIN program for computer aided design, which combines the ARPSO algorithm's design methodology with the TMEM design theoretical searching and finding for the best solution on each bearing load and position located at the initial design stage of shafting arrangement and its alignment subsequently.

A brand new propulsion shafting model will, of course, present and propose better design results than the original design objectives when using the uniform distribution of each supporting bearing load and bearing pressure of this new propulsion shafting

system. In this new output model, it also supplies a brand new optimal adjusted value for vertical bearing off-set and bearing arrangement on each new bearing location after carried out global optimization algorithm design on propulsion shafting system.

6.1 Shafting model for analysis and optimization

A real design case from the shipyard on the direct propulsion shafting shown in Figures 9 and 10, mainly consisting of the propeller, three (3) propulsion shafts coupled with shaft coupling, three (3) shaft couplings, two (2) shaft struts, one (1) stern tube bearing, and two (2) reduction gear bearings for output and input end shaft bearing on this propulsion system of high speed craft, will be employed in this design study.

Two shafting analysis models, the cold static condition and the hot running condition, will be carried out on the same design shafting model for analysis.

In the cold static shafting model, it is assumed that the shafting is in a straight position without any deflection and/or vertical off-set in each bearing point in the first design stage. Meanwhile, we need to input all the original design data from the shipyard into the ARPSO-SHAALIN program for the process of numerical calculation and optimization algorithm. Finally, we will obtain some optimal recommended design input data and results including each new bearing location, vertical off-set

value, bearing reaction force (load), bearing pressure and bending moment in each bearing point in the new design results for the shafting arrangement.

In the hot running condition of the shafting model, we will choose one set of the best design data obtained from the cold static shafting model and will adjust the vertical bearing off-set values to the input and output end of the reduction gear shaft bearing in accordance with the temperature rising in the propulsion shafting while it is operating in the running condition.

It is also necessary to input all the new design data for the hot running condition of the shafting model into the ARPSO-SHAALIN program for the process of numerical calculation and optimization algorithm again.

Finally, we will obtain some optimal output design results including each new bearing reaction force (load), bearing pressure and bending moment in each bearing point in these new design results for the shafting arrangement in the hot running condition.

Final verification and discussion of the optimal design results of the cold static and the hot running condition of the shafting model and their comparison with the original design results from the shipyard will be employed in this study for its design benefits and concerning also some issues that need to be improved in the future.

Figure 9 The direct propulsion shafting system [4]
Slika 9 Sustav direktnog propulzijskog osovinskog voda [4]

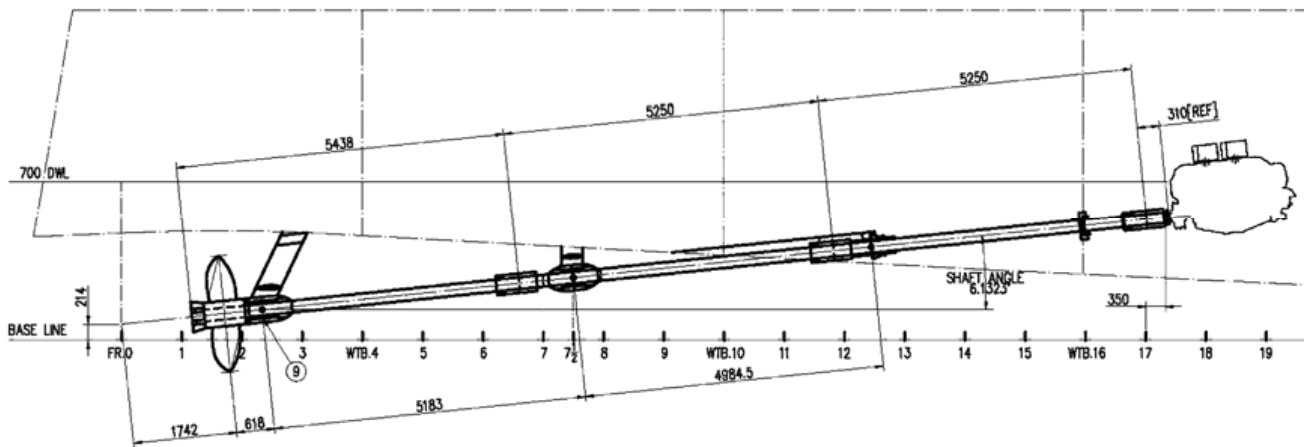
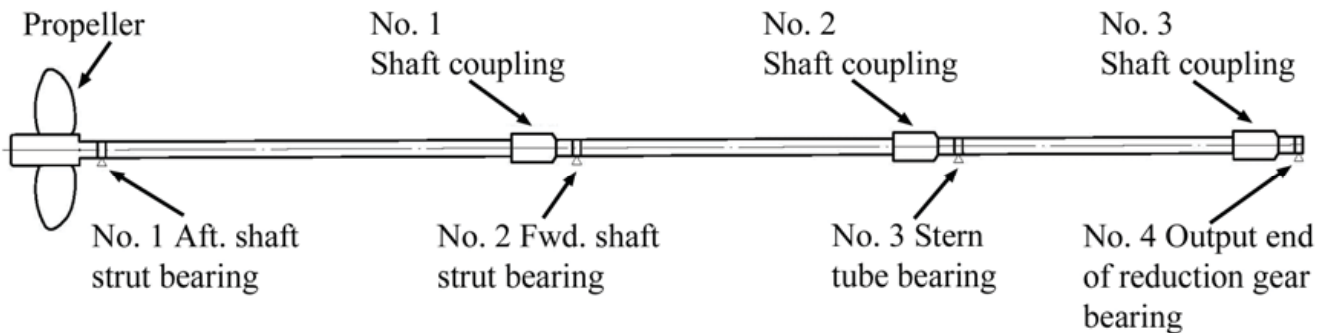

Figure 10 The illustration for direct propulsion shafting model
Slika 10 Prikaz modela direktnog propulzijskog osovinskog voda



6.2 ARPSO optimization algorithm in cold static condition of shafting line

As described in section 5, it is necessary to input some of design parameters, such as each section of shaft diameter, and number of shaft for coupling, shaft material specification, propeller weight, number and diameter of shaft coupling, supporting bearing numbers and locations, length of span on each supporting bearing etc, as shown in Figure 11.

This model of shafting analysis data input is for the numerical calculation process by TMEM Fortran program in order to get the calculation results for the next step of further analysis by ARPSO algorithm for the purpose of obtaining the optimal design values on each bearing off-set and new location of supporting point as the design output.

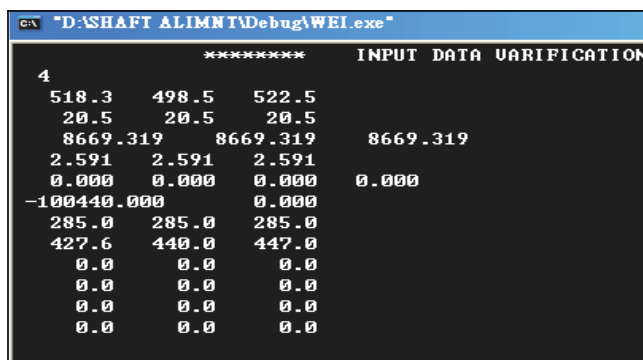

Figure 11 Input design data for propulsion shafting system
Slika 11 Ulazni projektni podaci za sustav propulzijskog osovinskog voda

Numerical calculation by TMEM design theory coding in Fortran program will be performed while all the input design data for the propulsion shafting system are completed as shown in Figure 11.

Each calculation output result by TMEM Fortran program will be shifted into the ARPSO global optimization algorithm program for further convergence to comply with our design objective and design criteria. We may get the global best design values through setting the searching space and diversity to updated each global best value on this propulsion shafting system.

By using many iteration steps, the search of the updated best global value is accomplished and then some optimal output design values are obtained by picked them up from the optimization results of ARPSO-SHAALIN program in the cold static straight shafting system as shown in Table 1 below.

6.3 Discussion of the results from ARPSO optimization algorithm in cold static condition of shafting line

Table 1 presents the result from the global optimization algorithm program, ARPSO-SHAALIN program, for the cold static condition of the straight shafting line consisting of: four (4) supporting bearing points from aft shaft strut bearing (bearing no.1), forward shaft strut bearing (bearing No. 2), stern tube bearing (bearing No. 3), and reduction gear output end shaft bearing (bearing No. 4).

It is clear that there are some changes in each original bearing off-set value and location after carried out ARPSO global optimization algorithm. It recommends that the new bearing location on forward shaft strut bearing (bearing No. 2) should be adjusted for about -154.1 mm towards the aft shaft strut bearing no.1, and the new bearing location on the stern tube bearing (bearing no. 3) should be adjusted for about -165.3 mm towards the forward shaft strut bearing no.2.

This optimization result also recommends that the new bearing off-set values on the forward shaft strut bearing (bearing No. 2) should be adjusted for about -2.664 mm lower than the original straight center shaft line. Also, the new bearing off-set values on the stern tube bearing (bearing no.3) should be adjusted for about -3.974 mm lower than the original straight center shaft line.

As the new design results in shafting alignment and in its new arrangement based on ARPSO-SHAALIN program, a new bearing load and bearing pressure of the new propulsion shafting system that are better than the original design from the shipyard are obtained. The design procedure is shown in Table 2.

In short, after successfully carrying out the ARPSO algorithm for the global propulsion shafting system, brand new shafting arrangement design data with the adjustment data for the supporting bearing locations and off-set values are obtained, which is obvious from the above comparison table.

From this table, we can clearly realize that each bearing reaction load and pressure are being rearranged and redistributed in a reasonable design range as it can possibly be.

Table 1 Results on ARPSO global optimization algorithm in cold static straight shafting line
Tablica 1 Rezultati ARPSO algoritma globalne optimizacije za direktni osovinski vod u hladnom statičkom stanju

Bearing Nos.	Shipyard original design bearing location (mm)	Shipyard original design bearing off-set (mm)	ARPSO new design bearing location (mm)	ARPSO new design bearing off-set (mm)	Force (N)	Moment (Nm)	Stress (N/mm ²)
No.1 Aft shaft strut bearing	0.00000E+00	0.00000E+00	0.00000E+00	0.00000E+00	18786	9843	0.183
No.2 Fwd shaft strut bearing	0.51830E+04	0.00000E+00	-0.1541E+03	-0.2664E+01	18844	- 9942	0.306
No.3 Stern tube bearing	0.10168E+05	0.00000E+00	-0.1653E+03	-0.3974E+01	18739	- 12477	0.305
No.4 Output end reduction gear bearing	0.15393E+05	0.00000E+00	0.00000E+00	0.00000E+00	6874	0.000	0.168

Table 2 Comparison table of bearing loads and bearing pressure between ARPSO algorithm and shipyard original design [5] in cold static condition

Tablica 2 Tablica usporedbe opterećenja i tlakova u ležaju za hladno statičko stanje, dobivenih pomoću ARPSO algoritma i iz originalnog projekta brodogradilišta [5]

Items (Cold static design)	Bearing Nos.	No.1 Aft shaft strut bearing	No.2 Fwd shaft strut bearing	No.3 Stern tube bearing	No.4 Output end reduction gear bearing
Bearing length (mm)		500	300	300	200
Shaft diameter (mm)		205	205	205	205
Shipyard design bearing load (N)		22035	14313	18482	7681
ARPSO design bearing load (N)		18786	18844	18739	6874
Shipyard design bearing pressure (N/mm ²)		0.215	0.233	0.301	0.187
ARPSO design bearing pressure (N/mm ²)		0.183	0.306	0.305	0.168
Rule's requirements (N/mm ²)		<0.55	<0.55	<0.55	<1.20

This is especially obvious in the case of No. 2 forward shaft strut bearing and No. 3 stern tube bearing, which commonly share the bearing load and pressure of a uniform positive value, reducing in such a way the No. 1 aft shaft strut bearing load in concentration edge point due to a big slop angle (θ) between the propeller shaft and the aft shaft strut bearing, and also to improving the non-uniform light design bearing load between the No. 2 forward shaft strut bearing and No.3 stern tube bearing from the original shipyard design.

Moreover, all the design output values in the cold static shafting line condition have been checked for compliance with different design criteria from the Rule's requirements of Classification Societies and Maker's design standards.

Subsequently, in Table 2 another main point is given, where each redistributed supporting bearing load, and each reproduced bearing pressure have such a uniform positive value, which proves that the design by means of this program can avoid the excessive bearing load on the No.1 aft shaft strut bearing due to a big slop angle (θ) between the propeller shaft and the No. 1 aft shaft strut bearing, as illustrated in Figure 12.

If there is a big slop angle (θ) between the propeller shaft and the aft shaft strut bearing, it will cause significant damage to the shaft bearing in operation and will increase the possibility of further damage to the propulsion shafting system at sea.

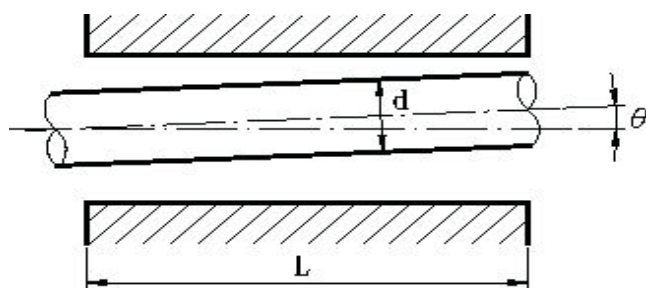

Figure 12 Maximum design slop angle (θ) between the propeller shaft and aft shaft strut bearing

Slika 12 Najveći kut nagiba (θ) između osovine brodske vijka i ležaja osovine u stražnjem skroku

Normally, the maximum design slop angle (θ) between the propeller shaft and the aft shaft strut bearing should not exceed

the design criteria from the requirements of High Speed Craft Code published in Classification Societies [6] defined as:

$$\theta \leq 3.0 \times 10^{-4} \text{ rad} \tag{19}$$

Concurrently, the maximum design bearing pressure (P) for the reinforced resin bearing material installed on aft end of the forward shaft strut bearing and in the stern tube bearing does not exceed in this design case the design criteria from the requirements of the High Speed Craft Code published in the Classification Societies [6] stipulated as:

$$P \leq 0.55 \text{ N/mm}^2 \tag{20}$$

As a result of numerical solution, and of a global optimization algorithm in this study case, we may check if the maximum design bearing load and bearing pressure on each supporting bearing are within Rule's requirements and Maker's design standards, which is in accordance with the design recommendations that are based on the above formulated and required design criteria.

6.4 ARPSO optimization algorithm in the hot condition of shafting line

In this paragraph we will adjust the off-set values on the reduction gear output end shaft bearing (bearing No.4) and the input end shaft bearing (bearing No.5) which is driven by the main engine for propulsion. According to the original design criteria from the shipyard, we need to raise for 1.85 mm the off-set value both in the reduction gear output end shaft bearing and the input end shaft bearing in order to figure out and analyze the new optimal design results for each bearing location and off-set values.

Moreover, we need to confirm if the each new bearing load and reaction force from the new shafting arrangement and alignment results in the cold static condition obtained by the ARPSO-SHAALIN program is better than in the original design. Table 3 shows some optimal output design values from the ARPSO-SHAALIN program as the optimization results in the hot shafting line condition.

Table 3 Results of ARPSO global optimization algorithm in the hot shafting line condition
 Tablica 3 Rezultati ARPSO algoritma globalne optimizacije za osovinski vod u vrućem stanju

Items Bearing Nos.	ARPSO new design bearing location (mm)	ARPSO new design bearing off-set (mm)	Fixed ARPSO design bearing location	Fixed ARPSO design bearing off-set	Force (N)	Moment (Nm)	Stress (N/mm ²)
No.1 Aft shaft strut bearing	0.00000E+00	0.00000E+00	0.00000E+00	0.00000E+00	18962	9843	0.185
No.2 Fwd shaft strut bearing	0.50289E+04	-0.2664E+00	0.00000E+00	0.00000E+00	17707	- 9059	0.288
No.3 Stern tube bearing	0.10003E+05	-0.3974E+00	0.00000E+00	0.00000E+00	21439	- 1603	0.349
No.4 Output end reduction gear bearing	0.15393E+05	0.18500E+00	0.00000E+00	0.00000E+00	2984	6083	0.073
No.5 Input end reduction gear bearing	0.16893E+05	0.18500E+00	0.00000E+00	0.00000E+00	5960	0.000	0.145

6.5 Discussion of the results from ARPSO optimization algorithm in the hot condition of shafting line

In this section, we will discuss how the main design purpose of this hot design shafting conditions is to make sure and verify that these design results are not only in compliance with all necessary design criteria from the Maker and Classification Societies, but also better than the original design.

Description of the design process from Table 3: we will adopt the new ARPSO shafting design data for a new shafting arrangement to lower the bearing off-set values from the shaft straight line for about -2.664 mm at the forward shaft strut bearing (bearing No.2), and about -3.974 mm at the stern tube bearing (bearing No.3) in the cold static initial condition. Meanwhile, we will also raise the bearing off-set value for 1.85 mm at the output end (bearing No.4) and the input end (bearing No.5) of the reduction gear shaft bearing due to temperature rising under the continuous running of the propulsion system including its gearing.

Simultaneously, we will also change and adjust the new bearing location on the forward shaft strut bearing (bearing

No.2) for -154.1 mm towards the aft shaft strut bearing (bearing No.1), and the new bearing location on the stern tube bearing (bearing No.3) should be adjusted for around -165.3 mm towards the forward shaft strut bearing (bearing No.2).

When all design parameters, recommended from the previous optimal design values from the ARPSO algorithm, as well as adjusted bearing off-set values at the output end (bearing No.4) and at the input end (bearing No.5) of the reduction gear shaft bearing due to the temperature rise during the continuous running of the propulsion system, including its gearing in the hot condition, are used, the final new design results from the ARPSO-SHAALIN program will be obtained.

From these new design results on the hot shafting alignment and its new arrangement based on the ARPSO-SHAALIN program, we will obtain new distributed bearing reaction load and bearing pressure.

Subsequently, a comparison of the bearing reaction loads in the cold static condition and the hot condition between the ARPSO algorithm and the shipyard original design in the cold static condition and the hot condition is summarized in Table 4.

Table 4 Comparison table of bearing reaction loads in cold static and hot condition between ARPSO algorithm and shipyard original design

Tablica 4 Tablica usporedbe reaktivnih sila u ležaju za slučaj hladnog statičkog i vrućeg stanja, dobivenih pomoću ARPSO algoritma i iz originalnog projekta brodogradilišta

Design Method	Bearing Nos.	No.1 Aft shaft strut bearing	No.2 Fwd shaft strut bearing	No.3 Stern tube bearing	No.4 Output end reduction gear bearing	No.5 Input end reduction gear bearing
ARPSO Algorithm in Cold Static Condition (N)		18786	18844	18739	6874	-----
ARPSO Algorithm in Hot Condition (N)		18962	17707	21439	2984	5960
Shipyard original design in Cold Static Condition (N)		22035	14313	18482	7681	-----
Shipyard original design in Hot Condition (N)		23611	11757	21306	3116	7724

Table 5 Comparison table of each bearing load and bearing pressure between ARPSO algorithm and shipyard original design in hot shafting condition

Tablica 5 Tablica usporedbe svakog pojedinačnog opterećenja i tlaka u ležaju za slučaj osovine u vrućem stanju, dobivenih pomoću ARPSO algoritma i iz originalnog projekta brodogradilišta

Bearing Nos.	No. 1 Aft shaft strut bearing	No. 2 Fwd shaft strut bearing	No. 3 Stern tube bearing	No. 4 Output end reduction gear bearing	No. 5 Input end reduction gear bearing
Items (Hot condition)					
Bearing length (mm)	500	300	300	200	200
Shaft diameter (mm)	205	205	205	205	205
Shipyard design bearing load (N)	23611	11757	21306	3116	7724
ARPSO design bearing load (N)	18962	17707	21439	2984	5960
Shipyard design bearing pressure (N/mm ²)	0.230	0.191	0.346	0.076	0.188
ARPSO design bearing pressure (N/mm ²)	0.185	0.288	0.349	0.073	0.145
Rules requirements (N/mm ²)	<0.55	<0.55	<0.55	<0.55	<1.20

It should be also noted that the hot condition of the shafting alignment is designed by means of the new arrangement of the shafting design data, as given in Table 1, having a new cold static shafting line (new bearing locations and new bearing off-set design values), and taking into account the raising of the bearing off-set valves on the output end of the reduction gear shaft bearing, and considering the propulsion system in a continuous operation running with a temperature rise at these gear bearings.

As the design result of numerical solution and the global optimization algorithm from ARPSO-SHAALIN program to this hot condition study case, we may check once again the results in the hot condition of the shafting system and check whether the maximum design bearing reaction force and pressure in each supporting bearing point fully comply with the Rules' requirements and Maker's design standard or not.

Finally, a comparison of bearing reaction loads and bearing pressure in the hot shafting condition between the ARPSO algorithm and the shipyard original design is summarized in Table 5 above.

From the above comparison table concerning the hot running condition, it can be concluded that the ARPSO algorithm also uniform and improves the unbalanced light bearing load distribution in the No.2 forward shaft strut bearing in order to make it equal to the load in the No.1 aft shaft strut bearing.

Nevertheless, it also reduces the damage risk in the No.1 aft shaft strut bearing by avoiding the excessive slop angle (θ) between the propeller shaft and the aft shaft strut bearing in the cold static shafting condition.

Hence, the one of the design objectives by ARPSO-SHAALIN design program for obtaining the uniform distribution values for each bearing reaction force (load), and minimum bearing pressure in a positive design range is verified with satisfactory result.

Moreover, it also provides the optimal adjusted bearing location and off-set value after the new propulsion shafting is recreated and arranged.

Finally, the design criteria for the propulsion shafting in the cold static condition and the hot running condition are operating

within the limitation design range of each bearing load, bearing pressure, and are also in compliance with the Maker's design standards and Rules' requirement from Classification Societies, which has also been proved in this study.

7 Conclusions

When comparing the design results from the ARPSO algorithm and also from the ARPSO-SHAALIN program with a real design case of shafting alignment done by the shipyard, it has been shown and verified that some of the optimal design values on the shafting arrangement and alignment can be reproduced and recreated, obtaining a better design than the original one from the shipyard.

In other words, we may choose and double check the new optimal design values for each new bearing off-set and new location design values, doing in such a way the best optimal design of such a propulsion shafting system.

The benefits and major contributions of this study are summarized as follows.

- (1) Successful combining and integrating two design methodologies on TMEM continuous beam equations and ARPSO algorithm in this optimization algorithm design program herein called ARPSO-SHAALIN program in the initial design stage of shafting alignment searching for the optimal values on each bearing off-set and each bearing location in the propulsion shafting system.
- (2) Searching the diversity problems on multi-extremes and higher dimensional space, the ARPSO algorithm can display and contribute to a higher performance to find out the global best values and solutions efficiently in the design field of propulsion shafting alignment.
- (3) Reducing the working hours and manpower design costs, when using the shipyard trial-and-error design method for designing the propulsion shafting system, and moreover, reducing also the possibility of the propulsion shafting system damage due to the improper design.

References

- [1] WEI, W. M.: "Technical Research for Solving Shafting Alignment on Large Two Stroke Marine Diesel Main Engine", *Journal of Maritime Sciences*, Vol. 3, p. 67-113, 1995.
- [2] JUANG, S.-W., CHANG, M.-H.: "A Study on Shafting Alignment for High Speed Craft", 7th International Symposium on Marine Engineering, Tokyo, 2005.
- [3] RIGET, J., VESTERSTROM, Jakob-S.: "A Diversity-Guided Particle Swarm Optimizer - the ARPSO," *EVALife Technical Report*, Vol. 2, p.1-13, 2002.
- [4] ...: "K4300401 Shafting Arrangement", Ching Fu Shipbuilding Co., Ltd., 2000.
- [5] ...: "K4300404 Shaft Alignment Calculation", Luessen Asia Co., and Ching Fu Shipbuilding Co., Ltd., 2000.
- [6] ...: "Rules and Regulations for Classification of Special Service Craft", Part 13, Chapter 4, Lloyd's Register of Shipping (LR), 2011.

Nomenclature

- M : Bending moment on each supporting bearing [Nm]
 I : Moment of inertia on propulsion shaft [mm^4]
 L : Span length between each supporting bearing point [mm]
 i : Numbers of supporting bearing point
 W : Weight of distribution load of each shaft per unit length [N/mm]
 d : Diameter of each shaft [mm]
 E : Young's modulus of elasticity [N/mm^2]
 P_n : Concentrated load P_n on supporting bearing point N-1 [N]
 P_{N+1} : Concentrated load P_n on supporting bearing point N+1 [N]
 a : Length distance between concentrated load P_n to the supporting bearing point N-1 [mm]
 b : Length distance between concentrated load P_{N+1} to the supporting bearing point N+1 [mm]
 δ : Off-set values on each supporting bearing point to the shafting straight line on propulsion shafting system [mm]

- R_N : Reaction force on the left of supporting bearing point N [N]
 R'_N : Reaction force on the right of supporting bearing point N [N]
 θ_N : Deflection angle on the left of supporting bearing point N due to uniform load on the beam segment [rad]
 θ'_N : Deflection angle on the right of supporting bearing point N due to uniform load on the beam segment [rad]
 β_N : Offset influence angles on supporting bearing point of beam element due to an uneven shaft line [rad]
 β_{N+1} : Offset influence angles on supporting bearing point of beam element due to an uneven shaft line [rad]
 w : Inertia weight
 (r) : Current step iteration
 $(r + 1)$: Next step iteration
 C_1 : Personal best learning factor
 C_2 : Group best learning factor
 r_1, r_2 : Random value by uniform distribution between 0 and 1
 $x_{i,j}^{(r)}$: Current position of particle i
 $y_{i,j}^{(r)}$: Personal best position
 $\hat{y}_j^{(r)}$: Group best position
 N^p : Number of particles
 L^p : The longest diagonal value of the solution space
 N : Problem dimension
 $x_{i,j}$: The j^{th} component of i particle position
 \bar{x}_j : The j^{th} component of average position
 dr : Searching diversity
 d_{low} : Low searching diversity
 d_{high} : High searching diversity

Subscript

- j : the j^{th} component of position vector or velocity vector
 i : number of particle's position
 dr : searching diversity