

## Digitally twin driven ship cooling pump fault monitoring system and application case

Shaojuan Su<sup>\*</sup>, Zhe Miao, Yong Zhao, Nanzhe Song

<sup>1</sup> Naval Architecture and Ocean Engineering College, Dalian Maritime University, 116026, Dalian, Liaoning, China

### ARTICLE INFO

Editor-in-Chief: Prof. Nastia Degiuli

Associate Editor: PhD Ivana Martić

Keywords:

Digital twin

Ship cooling pump

Data-driven

Visualization monitoring

### ABSTRACT

The rise of digital twin technology has provided innovative methods for monitoring and optimizing ship cooling pumps. This paper proposes a digital twin-based framework for the status monitoring and visualization of ship cooling pumps. By establishing highly realistic physical and mathematical models and integrating actual operational data, a comprehensive virtual environment was created to simulate the operational status of ship cooling pumps. Using the random forest algorithm for data training and testing, the results showed that the root mean square error for the training set was 0.0037873, and for the test set, it was 0.008929, indicating high accuracy in predicting the status of cooling pumps. This system enables real-time monitoring, problem diagnosis, performance optimization, and decision support for cooling pumps. This study aims to leverage digital twin technology to design and apply a visualization monitoring system to enhance the intelligence of ship operation and maintenance.

### 1. Introduction

With the continuous advancement of technology and the rapid development of digitalization, digital twin technology, as an innovative engineering tool, is gradually attracting widespread attention and application [1-3]. This technology has been innovatively reviewed in various sectors of the maritime industry [4], including shipbuilding, offshore oil and gas, marine fisheries, and marine energy. In particular, in the maritime industry, the application of digital twin technology has become one of the key means to enhance vessel performance [5-7], optimize vessel design [8-10], and improve maintenance management [11]. In the maritime industry, digital twin technology can realize the innovative concept of real-time digital twinning, providing real-time predictive systems for maritime operations at sea. Lee et al. [12] by researching and developing real-time prediction systems for wave fields and maritime operations, it becomes possible to forecast sea wave and hydrodynamic performance, such as seaworthiness and maneuverability. This allows for real-time prediction of risks and optimal routes.

As one of the key components in a ship's propulsion system, the stable operation of the marine cooling pump is crucial for the performance and safety of the vessel. However, due to the complexity of the maritime operating environment and the diverse characteristics of cooling pump operations, various types of faults may

\* Corresponding author.

E-mail address: [ssjlpz@dlmu.edu.cn](mailto:ssjlpz@dlmu.edu.cn)

occur during their usage. These faults include pump impeller wear or damage, seal failure [13-16], and so on. Effectively monitoring, predicting, and optimizing the performance and operational status of marine cooling pumps has become one of the critical challenges in the field of maritime engineering.

In recent years, the interaction between digital twin technology and artificial intelligence in the pump field has gradually attracted researchers' attention. Intelligent sensors and predictive maintenance technologies have been widely applied to the monitoring and maintenance of centrifugal pumps[17]. For example, a study proposed a state estimation method that allows the hydraulic state of the pump system's operating speed to be inferred from pressure and flow measurements[18]. Additionally, for axial flow pump systems, a study proposed a numerical model to predict their overall characteristics, revealing the fluid dynamics characteristics of axial flow pump systems [19].

In the context of digital twin frameworks, researchers have proposed a framework for real-time monitoring of traditional machines, connecting isolated machines to an interconnected system and monitoring their status in real-time [20]. In terms of data management and visualization, studies have proposed a framework for visualizing environmental sensing data from lakes [21], as well as a graphical user interface for sensing weld growth [22]. Additionally, referring to the five-dimensional model of digital twins, a study proposed a visualization monitoring method for production lines [23].

Despite the extensive research in the aforementioned fields, studies combining digital twins and visualization for marine cooling pumps are still relatively scarce. Therefore, conducting researching on the digital twin visualization of marine cooling pumps is of great significance for enhancing ship safety and reducing maintenance costs.

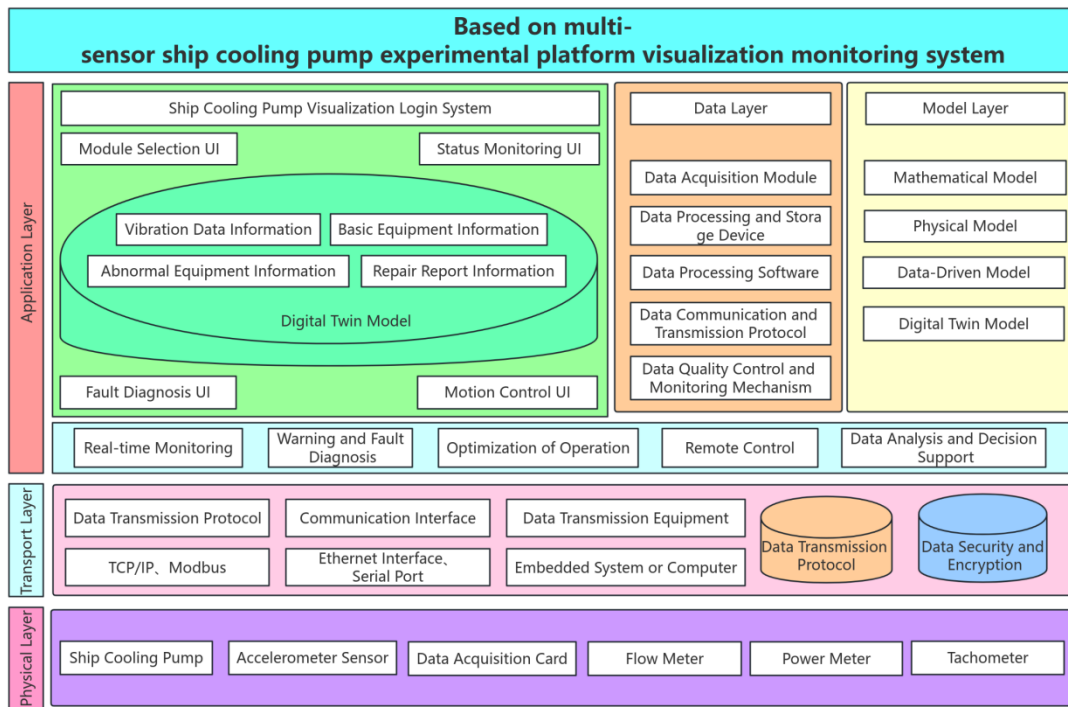
The main objective of this study is to develop and design a visualization framework applicable to marine cooling pumps using software such as Unity and Visual Studio. This framework visualizes the data, parameters, and status information from the digital twin model, allowing users to intuitively understand, analyze, and operate the actual system or process. By using marine cooling pumps as an example for the visualization framework demonstration, this study aims to showcase the practical application of digital twin technology in monitoring marine cooling pumps.

Combining digital twin technology with artificial intelligence, this study introduces a random forest algorithm to predict and diagnose the operational status of cooling pumps. The experimental results demonstrate that this method has high predictive accuracy. A visualization monitoring system is designed and implemented, allowing users to intuitively view the operational status, performance metrics, and fault diagnosis results of the cooling pumps, thereby enhancing the intelligence level of marine operation and maintenance. This study constructs highly realistic physical and mathematical models, and integrates actual operational data to create a comprehensive virtual environment. This virtual environment simulates the real-time operational status of marine cooling pumps, providing real-time monitoring and problem diagnosis capabilities.

This study demonstrates the effectiveness and practicality of a ship cooling pump status monitoring and visualization system framework based on digital twin technology. This system not only significantly enhances the monitoring and maintenance capabilities of ship cooling pumps but also provides crucial support for the intelligent development of the maritime industry.

## **2. Visualization monitoring system based on digital twin**

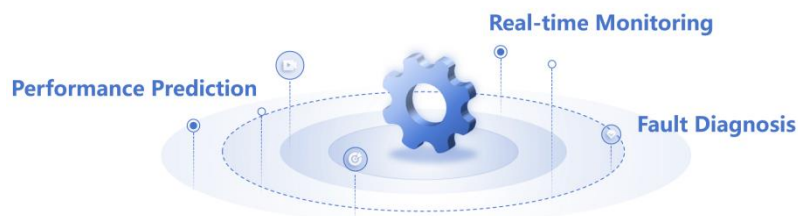
An innovative digital twin-driven ship cooling pump visualization monitoring system is proposed. It is an intelligent monitoring system integrated with digital twin technology and visualization technology, as shown in Fig. 1.



**Fig. 1** Visualization monitoring system for ship cooling pump experimental platform based on multi-sensor

### 2.1 Construction of ship cooling pump digital twin model

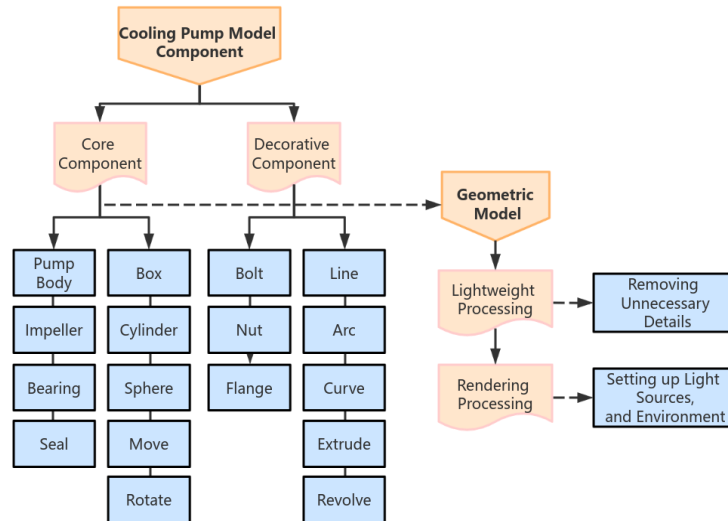
The cooling pump digital twin model refers to the virtual model [24] of the cooling pump constructed based on digital twin technology. By simulating the operation process and behavior of the cooling pump, real-time monitoring [25], malfunction diagnosis [26], and performance prediction [27] of the cooling pump status are achieved, as shown in Fig. 2.



**Fig. 2** Core functionalities of a digital twin system

#### 2.1.1 Division of geometric model components

Based on the geometric structure, material properties, operational principles, and physical parameters of the cooling pump, a modeling approach based on Rhino assembly is adopted in this paper to construct the twin model, as shown in Fig. 3. Due to the complexity of the model, it is divided into core components and decorative components. Core components, are primarily constructed, while decorative components, simpler, and can be added later. The geometric model starts construction with core components at its center and gradually expands, reducing the assembly process.

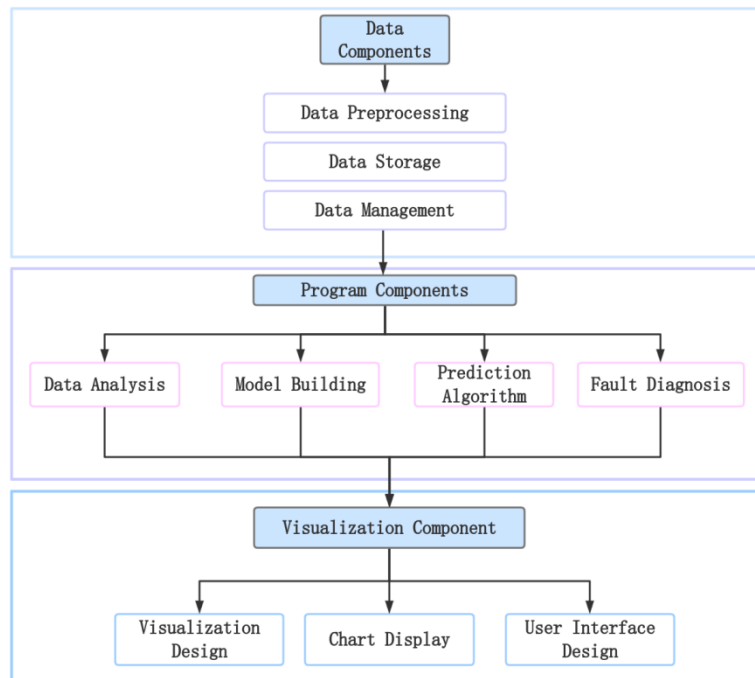


**Fig. 3** Division of geometric model components

2.1.2 Division of data-driven components

The data-driven components are divided into data components, program components, and visualization components, as shown in Fig. 4.

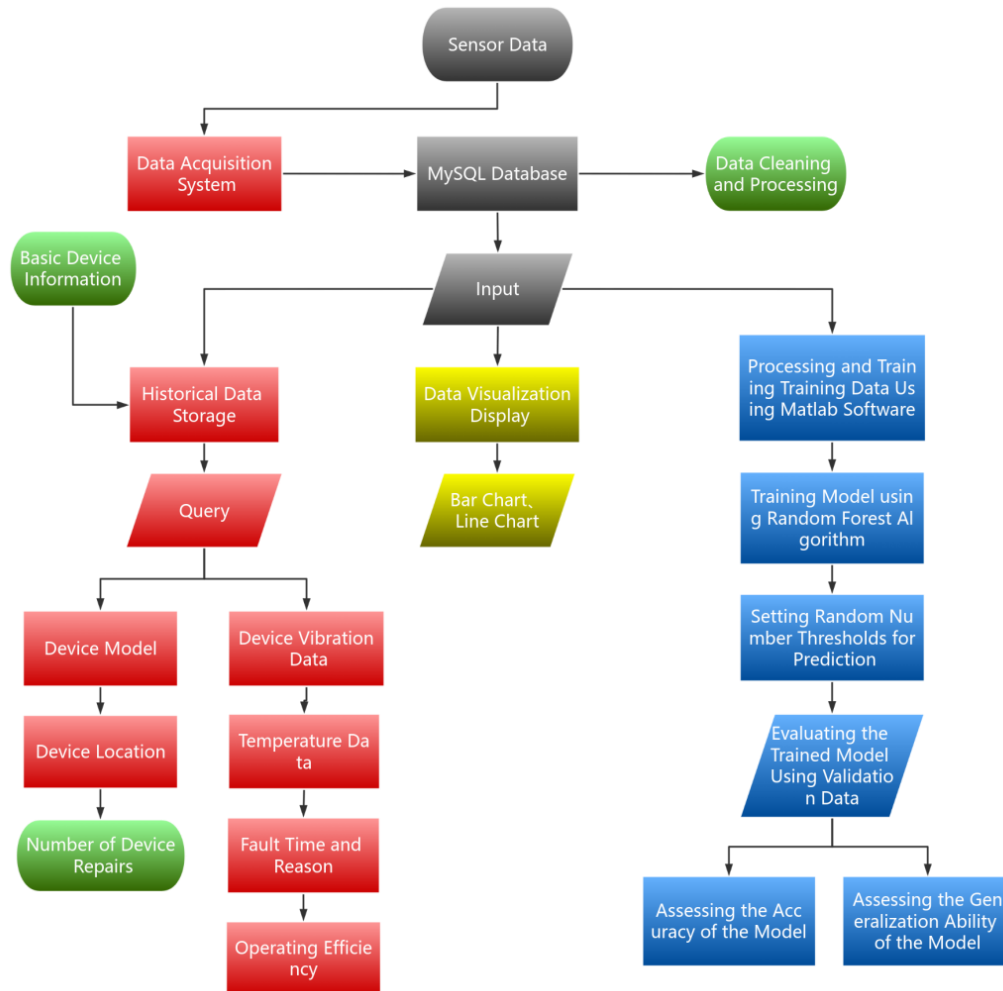
The data component is responsible for acquiring, storing, and processing the data collected by the monitoring system. It provides data interfaces for the program components and visualization components to call to obtain the required data. Data is retrieved by program components through the data interface from the data component and processed, analyzed, and computed to achieve data-driven functionality. The visualization component is responsible for presenting the data visually to the user.



**Fig. 4** Division of data-driven components

### 2.1.3 Data components

A prediction method based on random number thresholds is employed in this paper. The data component, combined with the random forest algorithm and MySQL database, enables the collection, preprocessing, modeling training, and predictive analysis of cooling pump system data, providing vital support for intelligent monitoring and prediction of the system. The relationships and workflow between its data components are illustrated in Fig. 5.



**Fig. 5** Data component workflow diagram

As per requirements, the data to be predicted is queried from the MySQL database. Features are extracted from the queried data and inputted into the trained random forest model. The trained model is then utilized to predict the features, resulting in the prediction of the cooling pump system's state or behavior.

### 2.1.4 Program Components

In response to the requirements of monitoring and controlling ship cooling pumps, the functionalities of the program components are determined, including data visualization and user interaction. As depicted in Fig. 6, the software architecture of the program components is designed, encompassing module division, data flow, and interface design, ensuring clarity of functions for each module and compatibility with interfaces of other components. The program components seamlessly integrate with the data-driven components, facilitating data visualization and user interaction functionalities for the ship cooling pump monitoring system, providing users with an intuitive monitoring interface and a satisfying user experience.

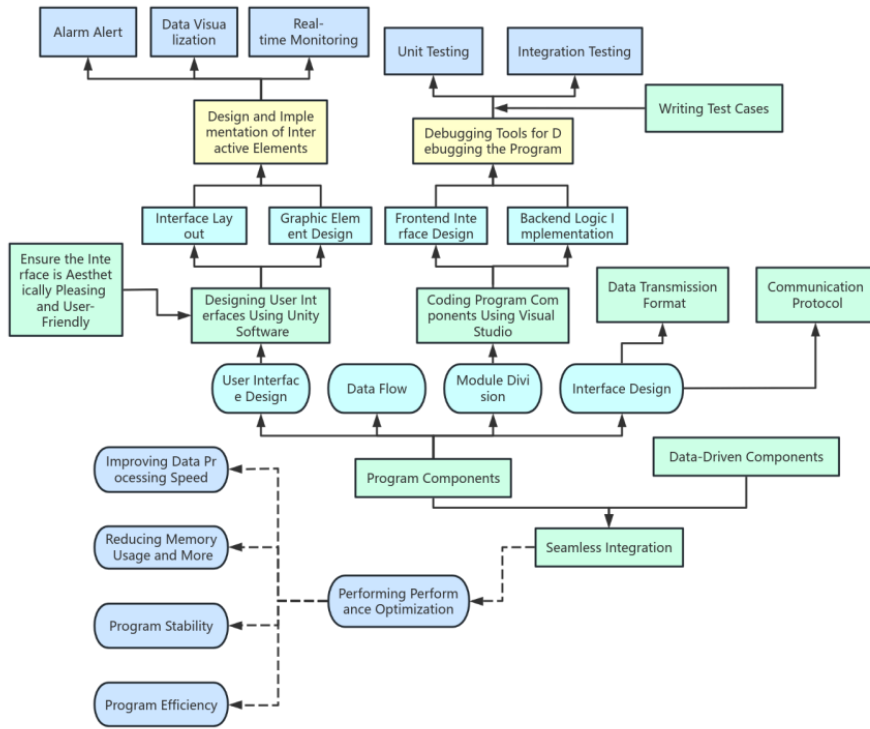


Fig. 6 Program component division

2.1.5 Visualization Components

In response to the requirements of the ship cooling pump monitoring system, the necessary data content and user interaction functionalities are showcased. Design software (such as Adobe XD, Sketch, etc.) is utilized to design the UI layout, and the designed UI layout files are imported into Unity. As illustrated in Fig. 7, the visualization component division enables the intuitive display of ship cooling pump data and a user-friendly operating interface, enhancing the usability and user experience of the monitoring system.

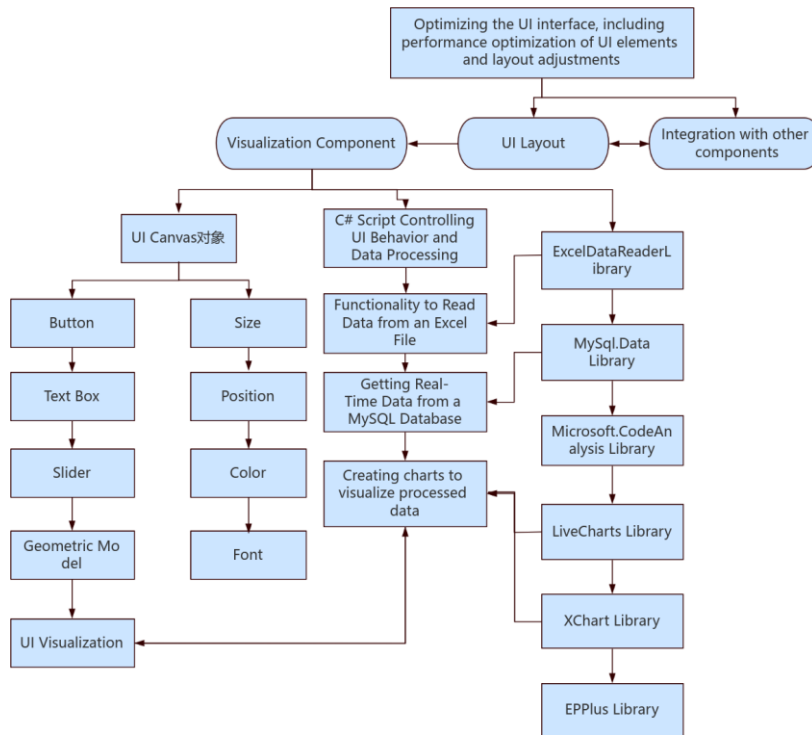


Fig. 7 Visualization component division

### 2.2 Visualization design architecture for marine cooling pump

The geometric model component, data component, program component, and visualization component are integrated and assembled to ensure the normal operation of data transmission and interaction functions among them, forming a complete digital twin model system. Real-time monitoring, data analysis, and visualization display of the ship cooling pump operating status are achieved. A visualization design framework for ship pumps is proposed in this paper, which utilizes Unity 3D and Visual Studio combined with libraries such as ExcelDataReader, LiveCharts, and Microsoft.CodeAnalysis, MySql.Data, XChart, EPPlus, etc., to establish a visualization interface. This enables operators to comprehensively understand the status, performance, and prediction results of the ship cooling pump system. Fig. 8 depicts the division of visualization components, where each component can be an independent entity, allowing for the reusability of other visualization interfaces.

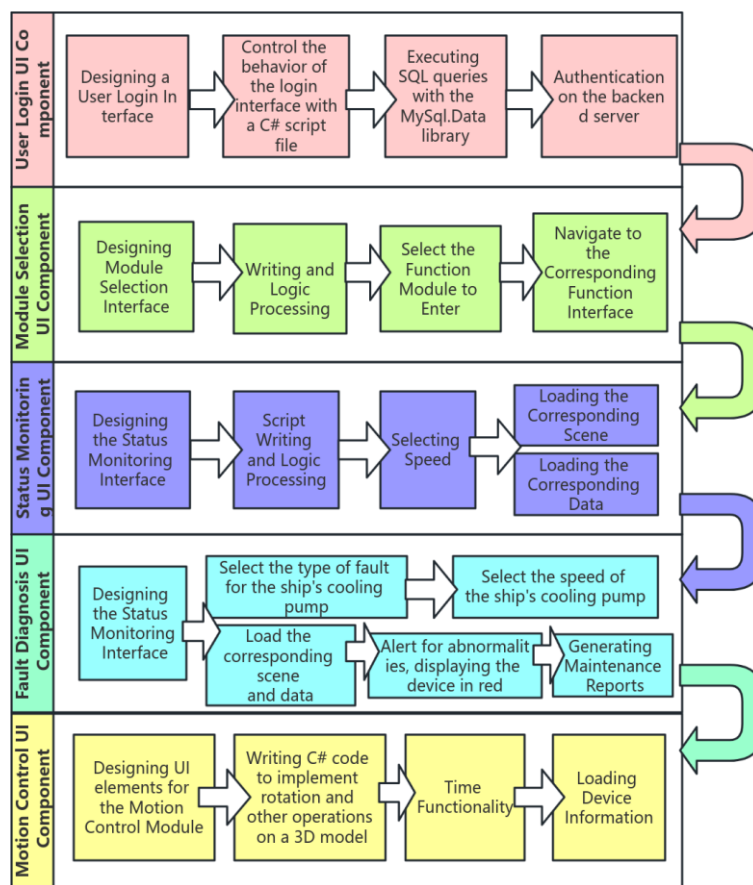


Fig. 8 Visual design architecture

### 3. Case study

In this section, the battery-powered seawater cooling pump will be used as the research case, and Table 1 presents the performance parameters of the ship cooling pump.

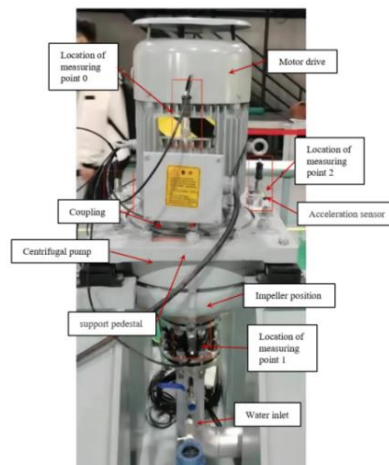
Table 1 Cooling Pump Performance Parameters

Parameters	Numerical	Parameter	Value
Motor power	11KW	Synchronous speed	1450r/min
Rated voltage	220V	Rated operating current	50A
Cooling pump flow rate	50m <sup>3</sup> /h	Cooling pump head	18m

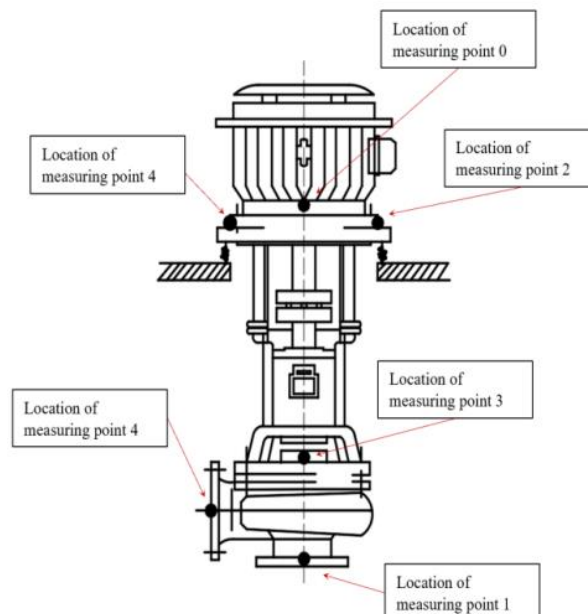
### 3.1 Twin model establishment

#### 3.1.1 Physical model

The experimental platform is mainly composed of a base, motor, cooling pump, power and control cabinet, sensor group, and data acquisition equipment. Measurement points are selected at locations where vibration energy is transmitted to the elastic foundation or other parts of the system. Data readings are taken in the direction of maximum flexibility and perpendicular to it to ensure maximum readings. Fig. 9 depicts a schematic diagram of the experimental setup, and Fig. 10 shows a sectional view of the cooling pump vibration sensor installation position. Smart sensors are installed at six locations: measurement point 1 at the inlet, measurement point 5 at the outlet, measurement point 0 at the base perpendicular to the center of the test bench, measurement point 4 at the left side of the motor base, measurement point 2 at the right side of the motor base, and measurement point 3 at the motor shaft center.



**Fig. 9** Schematic diagram of experimental setup



**Fig. 10** Cross-sectional view of vibration sensor installation positions for the cooling pump

Vibration data is collected from six measurement points, including six operating states: normal operation, loosening of the cooling pump base, fault in the outer ring of the cooling pump, fault in the bearing balls of the cooling pump, fault in the inner ring of the cooling pump, and imbalance of the cooling pump impeller.



Each measurement point comprises five sets of faulty data and one set of normal data, totaling 1.5 million data points. Fig. 11 Vibration data section display.

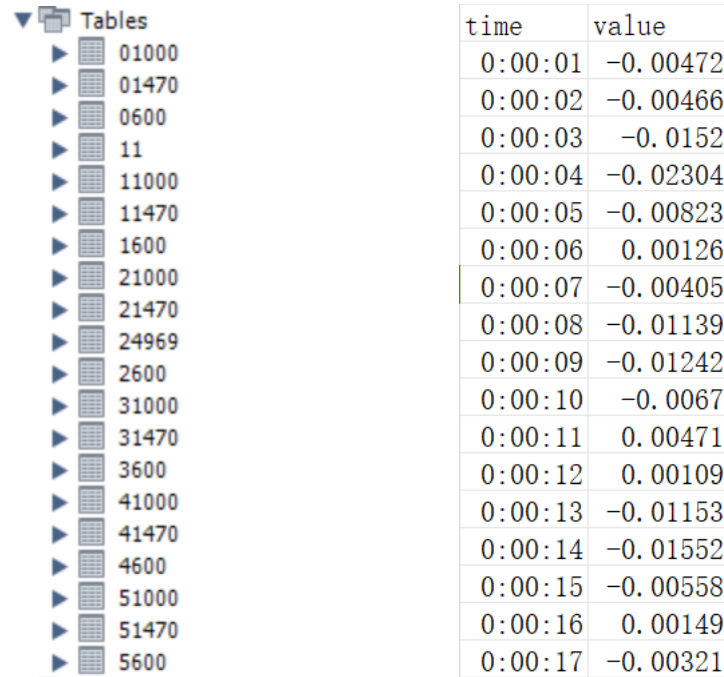


Fig. 11 Vibration data section display

### 3.1.2 Geometric model

In Rhino software, based on the design drawings and specifications of the ship cooling pump, the main body, impeller, shaft, and other key components of the 3D model are gradually constructed. The model's scale and dimensions are ensured to match those of the actual equipment, and its accuracy and authenticity are maintained through precise measurements and adjustments. The geometric model of the ship cooling pump, as shown in Fig. 12, is depicted.

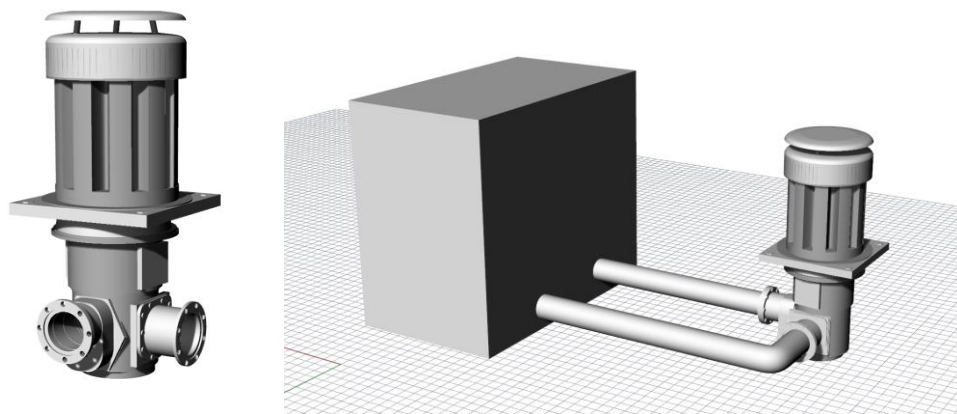
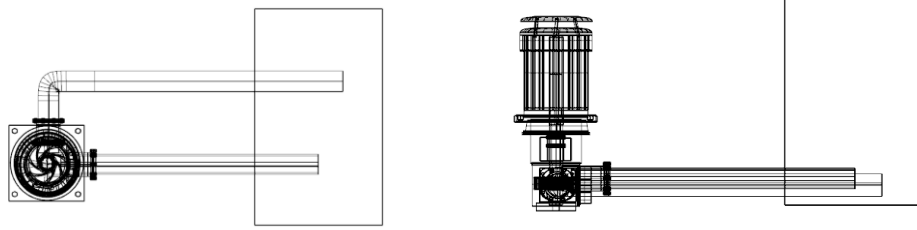
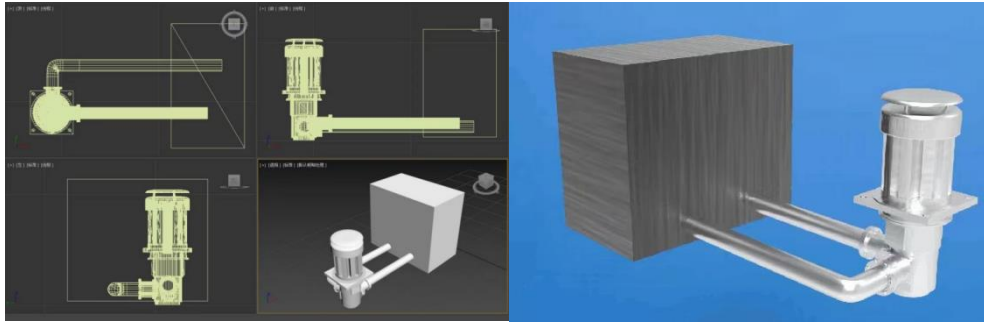


Fig. 12 Geometric model

The three-dimensional model established in Rhino is imported into 3Dmax for lightweight processing. This can reduce the complexity and file size of the model and improve rendering efficiency, as shown in Figs. 13 and 14. It is ensured that the lightweight of the model does not affect its appearance and structure.



**Fig. 13** Wireframe of the simplified model



**Fig. 14** Lightweight processing and rendering

### 3.1.3 Data model

In Matlab software, the random forest algorithm is used to predict the time series data of the ship cooling pump. The data is collected at normal operating states with speeds ranging from 400 r/min to 800 r/min, 800 r/min to 1200 r/min, and 1200 r/min to 1600 r/min. Each speed range comprises 100 sets of data, with each set containing 2500 samples, totaling 600 sets of experimental data.

The delay step size  $K_{im}$  was set to 16 and the prediction step size  $Z_{im}$  was set to 1. Next, a dataset was constructed, where each row contained  $K_{im}$ 's historical data points as input features and one target value. By traversing the data, features and target values were extracted, building a complete dataset  $res$ . The dataset was divided into a training set and a testing set in a 4:1 ratio, with the training set used for model training and the testing set used for model performance evaluation. To improve the training efficiency and prediction accuracy of the model, the data was normalized to scale it within the 0~1 range. The `mapminmax` function was used to normalize and denormalize the training and testing data separately. A Random Forest regression model was trained using the `TreeBagger` function. The number of decision trees was set to 100, the minimum leaf size was set to 1, and the out-of-bag error and feature importance computation functions were enabled. After the model training was completed, the feature importance was extracted.

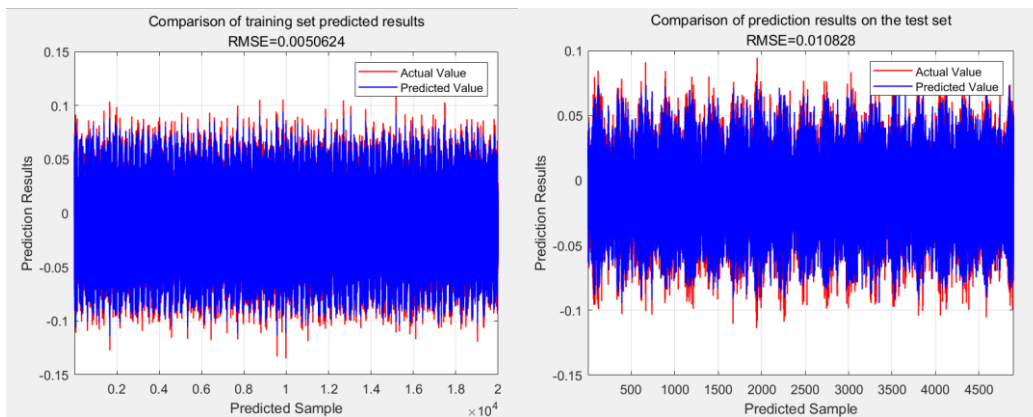
The trained model was used to make predictions on the training set and the testing set, respectively, obtaining the predicted results. The predicted results were then denormalized to restore them to the original data range, allowing for a more intuitive comparison between the predicted values and the actual values. The model's performance was evaluated by calculating the Root Mean Squared Error (RMSE), Mean Absolute Error (MAE), Mean Bias Error (MBE), and the coefficient of determination ( $R^2$ ). The evaluation results for the training and testing sets are shown in Table 2. A scatter plot of the training and testing sets was drawn, with Fig. 15 showing the relationship between the predicted values and the actual values. A comparison chart of the actual and predicted values for the training and testing sets was plotted, as shown in Fig. 16. Additionally, the error curve and the feature importance bar chart of the Random Forest model were plotted, as shown in Fig. 17.

**Table 2** Training results

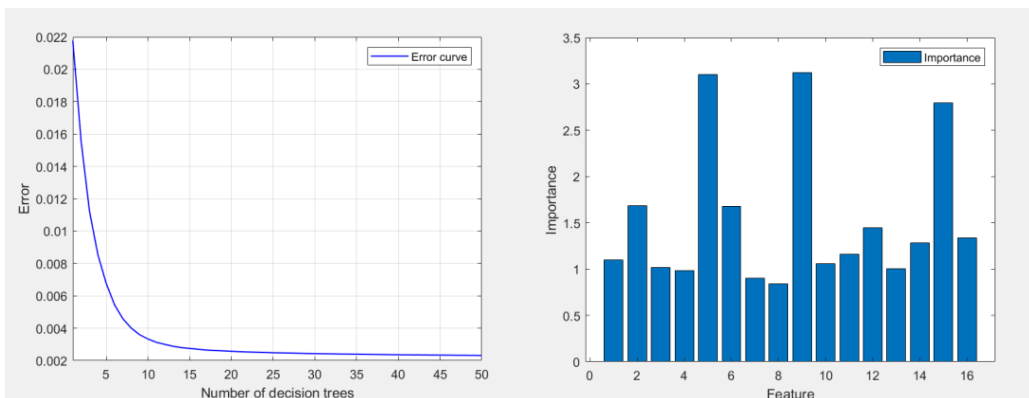
	Training Set	Test Set
Coefficient of Determination $R^2$	0.98625	0.93377
Mean Absolute Error (MAE)	0.0038185	0.0085258
Mean Bias Error (MBE)	1.4108e-06	1.0821e-05
Root Mean Square Error (RMSE)	0.0050624	0.010828



**Fig. 15** Comparison of predicted values and true values between training and test sets



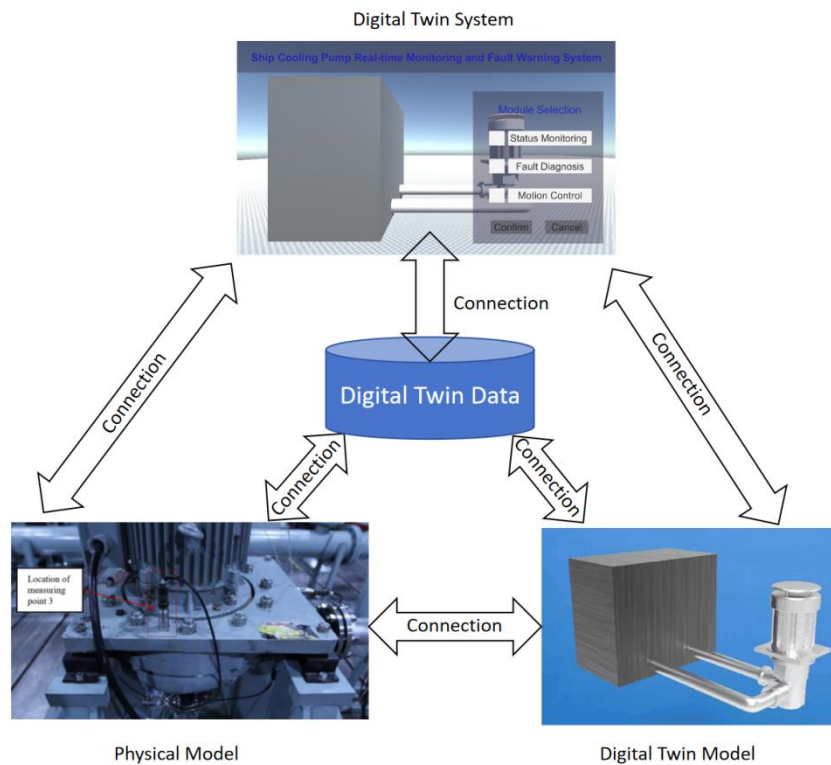
**Fig. 16** Comparison of predicted results between training and test sets



**Fig. 17** Decision tree numbers and features

### 3.2 Implementation of the digital twin-driven visualization monitoring system for ship cooling pumps

The implementation of the digital twin-driven ship cooling pump visualization monitoring system involves multiple steps and technologies. Sensor technology, data processing techniques, mathematical modeling, and visualization techniques [28] are comprehensively applied to achieve real-time monitoring, diagnosis, and prediction of the ship cooling pump system's operational status, as depicted in the simplified system shown in Fig. 18.



**Fig. 18** Simplified digital twin visualization system

The visualization monitoring interface and functions were designed using Unity3D, Visual Studio, and MySQL Workbench. In Visual Studio's Solution Explorer, various packages were installed, including MySQL.Data, System.Data.Common, System.IO, and UnityEditor. In Unity3D, the NuGet package was imported, and packages such as Google.Protobuf, K4os.Compression.LZ4, MySQL.Data, MySqlConnection, System.Runtime.Loader, and System.Text.Encoding were installed. This integration allowed for the connection between Unity3D, Visual Studio, and MySQL Workbench, enabling the visualization monitoring of the ship cooling pump. Using UI elements such as Raw Images, Text, and Buttons, interfaces for the ship cooling pump system were designed, including login interfaces, vibration status monitoring interfaces, operational fault diagnosis interfaces, and 3D model motion operations.

#### 3.2.1 Ship cooling pump system login system

The functionality of the user login interface was implemented through the UI system. Using the `OnLoginButtonClicked` method, when the user clicks the login button, the system checks if the entered username and password match the predefined values. If they match, the login interface is hidden, and the second interface is displayed; otherwise, an error message is shown. Using the `OnCancelButtonClicked` method, when the user clicks the cancel button, the input fields are cleared, and the login interface is returned. The display and hiding of UI elements are achieved through the `SetActive` method, and event handling methods are bound through the button's `OnClick` event, as shown in Fig. 19.

The switching of multiple UI interfaces is managed through a Canvas array. In the script, the `Start` method initializes the interface state, hiding all Canvases except for the first one. The `OnButtonClick` method receives a button index parameter, calculates the next Canvas index to display, and ensures the index is within a valid range. Then, it hides all Canvases, only shows the specified Canvas, and updates the current Canvas



index. By using the SetActive method to control the display and hiding of Canvases, this script achieves the dynamic switching of different UI interfaces, as shown in Fig. 20



Fig. 19 System login interface

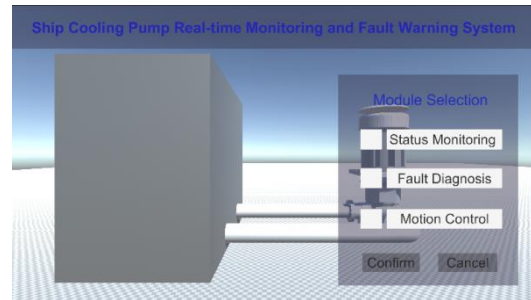


Fig. 20 Module selection interface

### 3.2.2 Vibration state monitoring

Using the MySQL Connector library to connect to the MySQL database, the latest data is periodically retrieved. After retrieving the data, it is stored in the data list, and the DrawChart method is called to update the chart. The RawImage component is used to display the curve chart. By controlling its size and position, the data curve is drawn and displayed. xOffset and yOffset are used to set the horizontal and vertical spacing between data points, controlling the display scale of the curve. lineColor and lineWidth set the color and width of the curve. The DrawChart method generates the curve chart based on the data points. First, it calculates the width and height of the data chart, creates a new Texture2D object, and fills its background with white. Then, by iterating through the data list, it uses the DrawLine method to draw the data curve. This method uses the Bresenham algorithm to draw line segments and sets the pixel color at the specified position. Finally, the generated Texture2D is applied to the RawImage component to display the curve chart.

Upon clicking the status monitoring button on the module selection interface, the user enters the status monitoring module. The status monitoring module contains three selection buttons, corresponding to the status monitoring of ship cooling pump speeds at 600 r/min, 1000 r/min, and 1470 r/min, as shown in Fig. 21. Figs. 22 and 23 depict the vibration data curves of the six measurement points of the ship cooling pump at different speeds.

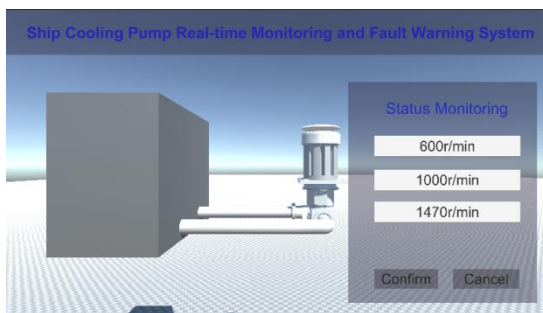


Fig. 21 Speed selection module

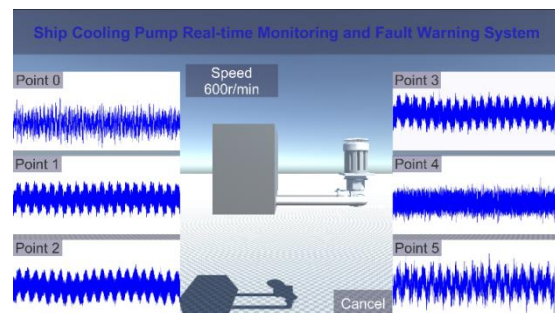


Fig. 22 Vibration data at 600 r/min

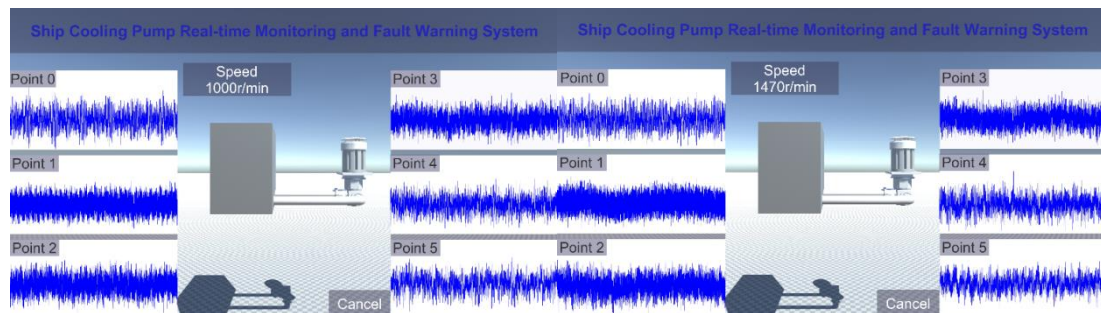
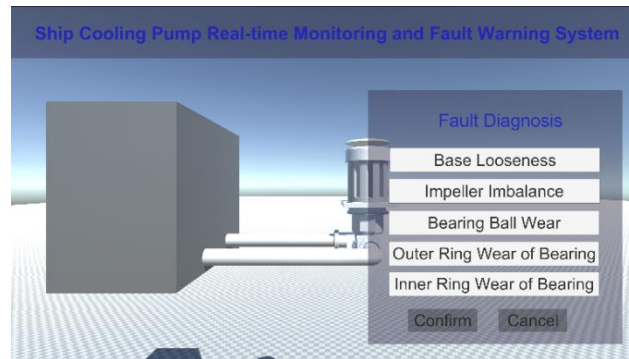


Fig. 23 Vibration data at 1000 r/min and 1470 r/min

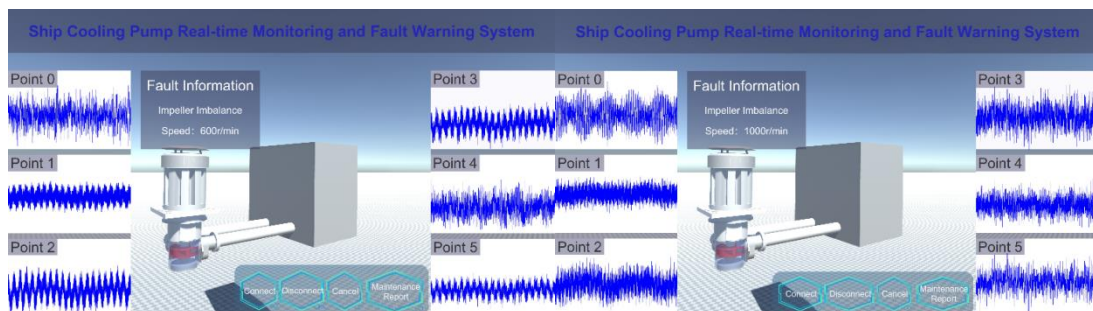
### 3.2.3 Operation fault diagnosis

Upon clicking the fault diagnosis module button on the module selection interface, the user enters the fault diagnosis module, as illustrated in Fig. 24.

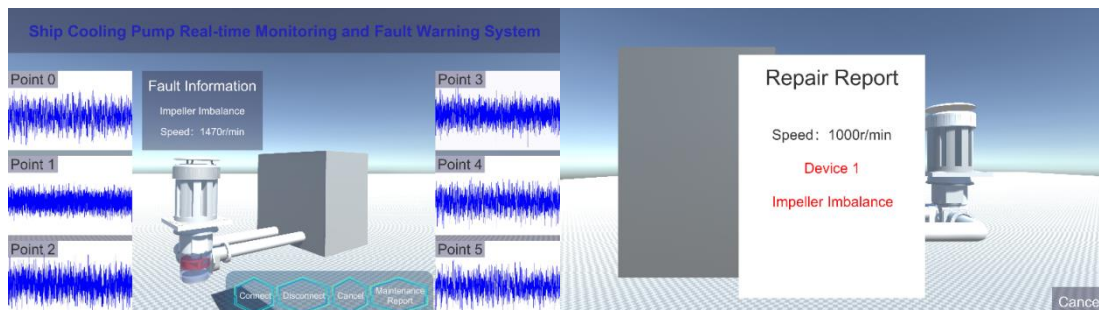


**Fig.24** Fault diagnosis module

Based on the data collected during the normal operation of the ship cooling pump, the vibration range of each measurement point is calculated, and simultaneously constrained within the digital twin system. Real-time data is used to predict the next vibration data. If the vibration data exceeds this range, a warning is issued, indicating the location of the equipment with abnormal data, and the equipment is highlighted in red. Taking two faults, impeller imbalance, and bearing inner ring wear, as examples, as shown in Figs. 25-28, when a fault occurs, the system issues a warning, and personnel can view the vibration data of the six measurement points through the visualization interface. The location of the fault is highlighted in red for warning. If there are obstructing components at the fault location, they become transparent. In the fault visualization interface, clicking the maintenance report generation button generates the corresponding fault report.



**Fig. 25** Vibration data for impeller imbalance at 600 r/min and 1000 r/min



**Fig. 26** Vibration data for impeller imbalance at 1470 r/min and repair report

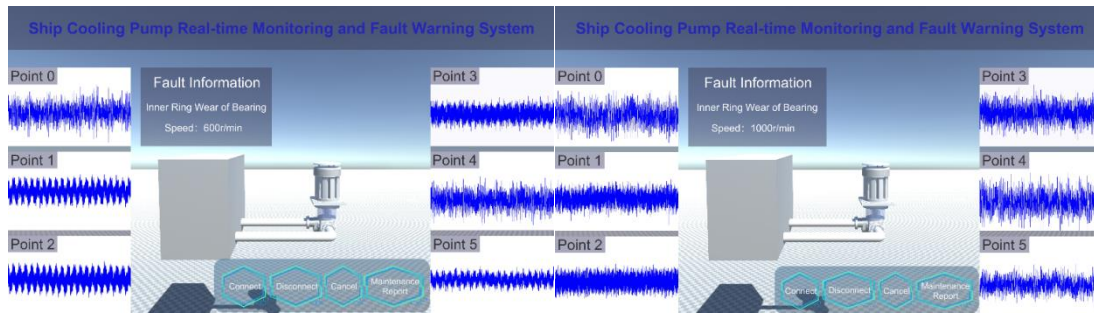


Fig. 27 Vibration data for inner ring wear at 600 r/min and 1000 r/min

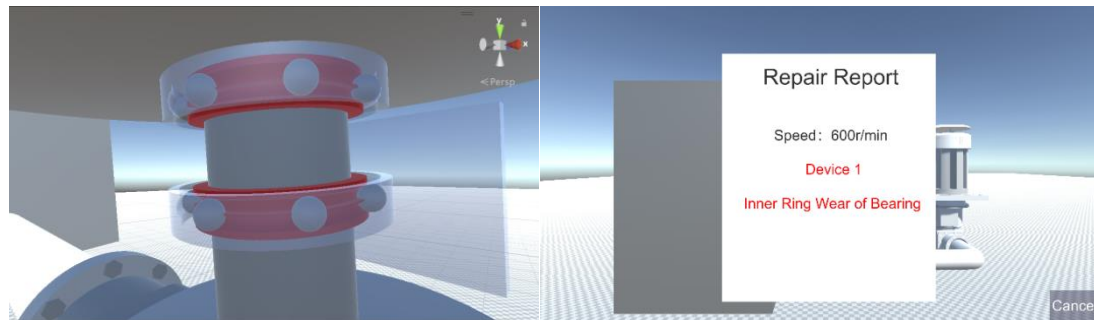


Fig. 28 Bearing fault display and maintenance report

### 3.2.4 Three-dimensional model operation

Upon entering the motion operation module, various information about the ship cooling pump is displayed on the upper left side. Various buttons on the lower left side allow for comprehensive movement of the three-dimensional model to facilitate clearer inspection of the various structures of the ship cooling pump. Clicking the equipment details button leads to the equipment information interface of the ship cooling pump, as shown in Fig. 29.

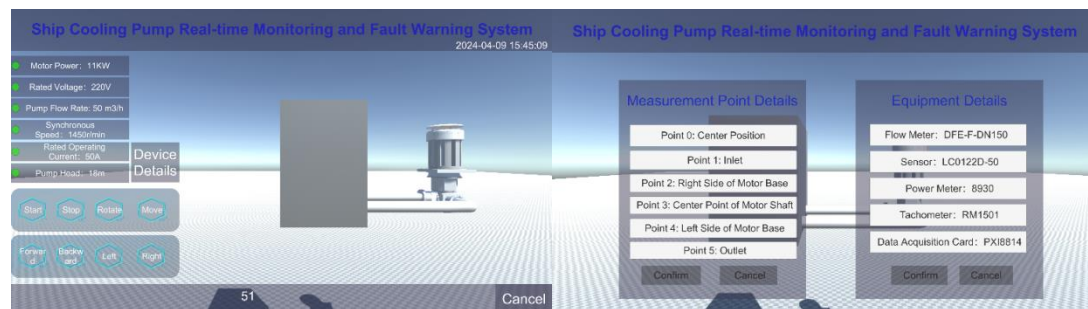


Fig. 29 Motion operation module and device details

## 4. Conclusion

The purpose of this paper is to deeply study the design and application of visual monitoring of marine cooling pump systems based on digital twins. Through digital twin technology, highly realistic physical and mathematical models have been established, combined with actual operational data, achieving comprehensive monitoring of the ship cooling pump system and simulation in a virtual environment. Based on the research status and practical requirements analysis of ship cooling pump equipment status monitoring visualization, a ship cooling pump status monitoring visualization system framework centered on digital twin technology is proposed, providing an effective solution and system architecture for real-time monitoring. Combining existing digital twin technology and artificial intelligence technology to establish a highly realistic and intuitive visualization monitoring system, the system displays key parameters such as vibration data and flow rate, achieving comprehensive monitoring of the ship cooling pump system. It provides ship engineers and operators with real-time and intuitive system understanding, offering more intelligent and sustainable



solutions for ship operators, thereby reducing the risk of potential failures, enhancing system maintainability and overall efficiency, and promoting the comprehensive and real-time ship cooling pump monitoring and prediction system.

The main contributions of this study are as follows:

(1) This study proposes a comprehensive digital twin model that utilizes historical fault data and advanced analytical techniques to monitor and predict faults in ship cooling pumps.

(2) An experimental platform was established to rigorously test and validate the digital twin system, ensuring its reliability and effectiveness in real-world scenarios.

(3) The system incorporates numerical analysis, artificial intelligence, and virtual modeling to provide detailed visualization of pump conditions, facilitating timely inspection, maintenance, and fault prevention.

(4) By providing real-time fault reports and visualizing fault locations, our system significantly improves the operational efficiency, safety, and service quality of maritime operations.

The next step is to further develop and test the system to improve it. References and arguments will be provided for real-time dynamic decision control problems of other physical entities. Finally, attention will be given to the future development trends of ship cooling pump monitoring technology and its potential impact on the maritime industry.

## REFERENCES

- [1] Botín-Sanabria, D. M., Mihaita, A.-S., Peimbert-García, R. E., Ramírez-Moreno, M. A., Ramírez-Mendoza, R. A., Lozoya-Santos, J. d. J., 2022. Digital twin technology challenges and applications: A comprehensive review. *Remote Sensing*, 14(6), 1335. <https://doi.org/10.3390/rs14061335>
- [2] Fang, X., Wang, H., Liu, G., Tian, X., Ding, G., Zhang, H., 2022. Industry application of digital twin: From concept to implementation. *The International Journal of Advanced Manufacturing Technology*, 121(7), 4289-4312. <https://doi.org/10.1007/s00170-022-09632-z>
- [3] Zhang, R., Wang, F., Cai, J., Wang, Y., Guo, H., Zheng, J., 2022. Digital twin and its applications: A survey. *The International Journal of Advanced Manufacturing Technology*, 123(11), 4123-4136. <https://doi.org/10.1007/s00170-022-10445-3>
- [4] Lv, Z., Lv, H., Fridenfalk, M. 2023. Digital twins in the marine industry. *Electronics*, 12(9), 2025. <https://doi.org/10.3390/electronics12092025>
- [5] Karatuğ, Ç., Tadros, M., Ventura, M., Soares, C. G., 2023. Strategy for ship energy efficiency based on optimization model and data-driven approach. *Ocean Engineering*, 279, 114397. <https://doi.org/10.1016/j.oceaneng.2023.114397>
- [6] Xie, C., Zhou, L., Ding, S., Liu, R., Zheng, S., 2023. Experimental and numerical investigation on the self-propulsion performance of polar merchant ship in the brash ice channel. *Ocean Engineering*, 269, 113424. <https://doi.org/10.1016/j.oceaneng.2022.113424>
- [7] Dinariyana, A., Deva, P. P., Ariana, I., Handani, D. W., 2022. Development of model-driven decision support system to schedule underwater hull cleaning. *Brodogradnja*, 73(3), 21-37. <https://doi.org/10.21278/brod73302>
- [8] Bassam, A. M., Phillips, A. B., Turnock, S. R., Wilson, P. A., 2023. Artificial neural network-based prediction of ship speed under operating conditions for operational optimization. *Ocean Engineering*, 278, 114613. <https://doi.org/10.1016/j.oceaneng.2023.114613>
- [9] Kondratenko, A. A., Kujala, P., Hirdaris, S. E., 2023. Holistic and sustainable design optimization of Arctic ships. *Ocean Engineering*, 275, 114095. <https://doi.org/10.1016/j.oceaneng.2023.114095>
- [10] Alvarado, D. R., Paternina, L. A., Paipa, E. G., 2022. Synthesis model for the conceptual design of inland cargo vessels to operate on the Magdalena river. *Brodogradnja*, 73(4), 13-37. <https://doi.org/10.21278/brod73402>
- [11] Esa, M. A. M., Muhammad, M., 2023. Adoption of prescriptive analytics for naval vessels risk-based maintenance: A conceptual framework. *Ocean Engineering*, 278, 114409. <https://doi.org/10.1016/j.oceaneng.2023.114409>
- [12] Lee, J.-H., Nam, Y.-S., Kim, Y., Liu, Y., Lee, J., Yang, H., 2022. Real-time digital twin for ship operation in waves. *Ocean Engineering*, 266, 112867. <https://doi.org/10.1016/j.oceaneng.2022.112867>
- [13] Kim, Y.-C., Paek, N.-I., Ri, B.-G., O, R.-H., 2024. Improvement of quality and yield for investment casting of centrifugal pump impeller by tilting mold and optimizing runner/riser system. *The International Journal of Advanced Manufacturing Technology*, 130(5), 2369-2379. <https://doi.org/10.1007/s00170-023-12839-3>
- [14] Tandel, R. R., Patel, R. N., Jain, S. V., 2023. Correlation development of erosive wear and silt erosion failure mechanisms for the pump as a turbine. *Engineering Failure Analysis*, 153, 107610. <https://doi.org/10.1016/j.engfailanal.2023.107610>



- [15] Wang, Y., Wang, X., Chen, J., Li, G., Liu, H., Xiong, W., 2022. An experimental insight into dynamic characteristics and wear of centrifugal pump handling multi-size particulate slurry. *Engineering Failure Analysis*, 138, 106303. <https://doi.org/10.1016/j.engfailanal.2022.106303>
- [16] Wei, L., Wang, C., Shi, W., Zhao, X., Yang, Y., Pei, B., 2017. Numerical calculation and optimization designs in engine cooling water pump. *Journal of Mechanical Science and Technology*, 31, 2319-2329. <https://doi.org/10.1007/s12206-017-0428-2>
- [17] Chen, L., Wei, L., Wang, Y., Wang, J., Li, W., 2022. Monitoring and predictive maintenance of centrifugal pumps based on smart sensors. *Sensors*, 22(6), 2106. <https://doi.org/10.3390/s22062106>
- [18] Bonilla, C. A., Zanfei, A., Brentan, B., Montalvo, I., Izquierdo, J., 2022. A digital twin of a water distribution system by using graph convolutional networks for pump speed-based state estimation. *Water*, 14(4), 514. <https://doi.org/10.3390/w14040514>
- [19] Zhang, X., Tang, F., 2022. Investigation of hydrodynamic characteristics of coastal axial flow pump system model under full working condition of forward rotation based on experiment and CFD method. *Ocean Engineering*, 253, 111286. <https://doi.org/10.1016/j.oceaneng.2022.111286>
- [20] Wang, K.-J., Lee, Y.-H., Angelica, S., 2021. Digital twin design for real-time monitoring—a case study of die cutting machine. *International Journal of Production Research*, 59(21), 6471-6485. <https://doi.org/10.1080/00207543.2020.1817999>
- [21] Chen, H., Fang, C., Xiao, X., 2023. Visualization of Environmental Sensing Data in the Lake-Oriented Digital Twin World: Poyang Lake as an Example. *Remote Sensing*, 15(5), 1193. <https://doi.org/10.3390/rs15051193>
- [22] Wang, Q., Jiao, W., Zhang, Y., 2020. Deep learning-empowered digital twin for visualized weld joint growth monitoring and penetration control. *Journal of Manufacturing Systems*, 57, 429-439. <https://doi.org/10.1016/j.jmsy.2020.10.002>
- [23] Li, H., Yang, Y., Zhang, C., Zhang, C., Chen, W., 2023. Visualization Monitoring of Industrial Detonator Automatic Assembly Line Based on Digital Twin. *Sustainability*, 15(9), 7690. <https://doi.org/10.3390/su15097690>
- [24] Sano, M., 2023. Mathematical model and simulation of cooperative manoeuvres among a ship and tugboats. *Brodogradnja*, 74(2), 127-148. <https://doi.org/10.21278/brod74207>
- [25] Zhang, Y., Wang, W., Zhang, H., Li, H., Liu, C., Du, X., 2022. Vibration monitoring and analysis of strip rolling mill based on the digital twin model. *The International Journal of Advanced Manufacturing Technology*, 122(9), 3667-3681. <https://doi.org/10.1007/s00170-022-10098-2>
- [26] Xue, R., Zhang, P., Huang, Z., Wang, J., 2022. Digital twin-driven fault diagnosis for CNC machine tool. *The International Journal of Advanced Manufacturing Technology*, 1-14. <https://doi.org/10.1007/s00170-022-09978-4>
- [27] Xiong, M., Wang, H., Fu, Q., Xu, Y., 2021. Digital twin-driven aero-engine intelligent predictive maintenance. *The International Journal of Advanced Manufacturing Technology*, 114(11), 3751-3761. <https://doi.org/10.1007/s00170-021-06976-w>
- [28] Eškinja, Z., Mišković, I., Andročec, V., 2008. Modular Wavemaker Design for Harbours and Ships Physical Model Testing. *Brodogradnja*, 59(2), 131-135.